

national**grid**

Specifications for Electrical Installations 2025

**Covering National Grid's Service
Areas in Massachusetts (MA)
and New York (NY)**

Electric System Bulletin No. 750



Our assistance is just a phone call away!

- ✓ Help is as close as your phone. Call our local National Grid office for useful information and assistance whenever you have questions on information in this booklet.
- ✓ While you're planning electrical and mechanical systems for your next project, our representatives will work closely with you and your clients.
- ✓ We'll provide detailed analysis or supplemental data on all types of electrical installations.
- ✓ We'll give you valuable aid before final plans are made on heating, cooling, wiring and lighting. And most important, we will suggest ways to conserve energy.
- ✓ A call to National Grid will help you help yourself. Call today!

We're available 24 hours a day, every day!

Customer Service Center	New York	Massachusetts
Phone Number and Hours of Operation	1-800-642-4272 Mon-Fri 7:00 am – 7:00 pm After 7:00 pm & Wknds – Emergency only	1-800-322-3223 Mon-Fri 7:00 am – 7:00 pm Saturday 7:00 am – 5:00 pm
Fax	1-315-460-9270 (for new service applications only)	1-508-357-4730
Mailing Address	National Grid Customer Service Center 300 Erie Boulevard W. Syracuse, NY 13202-4250	National Grid Customer Service Center PO Box 960 Northborough, MA 01532-0960
Non-English-Speaking Customers Para Clientes que hablan Español	1-800-561-6672	1-800-322-3223
Hearing/Speech-Impaired Customers	711	
Specialized Commercial & Industrial Business Group	1-800-664-6729 Mon-Fri 8:00 am – 5:00 pm	Not Applicable
Emergency Numbers – does not replace 911 emergency medical services		
Life-Threatening Electric Emergency	1-800-892-2345	1-800-465-1212
Life-Threatening Gas Emergency		1-800-233-5325
Power Outages	1-800-867-5222	1-800-465-1212
Contractor Services For Order Initiation and Inspection Release	1-800-260-0054 1-315-350-3967 Fax https://gridforce.my.site.com/electric/s/	customerelectricconnectionsny@nationalgrid.com Mon-Fri 7:30 am – 5:00 pm
By Phone		1-800-375-7405 Mon-Fri 8:00 am – 4:30 pm
View/Upgrade/Demo and Inspection Release Portal	https://gridforce.my.site.com/electric/s/	
By Fax	1-800-882-0322 Using Electric Service Request Form	1-888-266-8094
Online by Internet	https://gridforce.my.site.com/electric/s/article/Electric-Specifications	
Customer Order Fulfillment	1-800-664-6729 or 1-800-260-0054 (for assistance with pending electric service requests)	
For Electric Inspectors, to release a municipal wiring inspection	1-800-375-7405 NE Only; 1-800-664-6729 NY Mon-Fri 8:00 am – 4:30pm 24-hour automated system. *For single service requests only.	
New Residential or Commercial Developments	customerelectricconnectionsny@nationalgrid.com (To e-mail AutoCAD or MicroStation drawings – NY Only)	workrequest@nationalgrid.com (MA)
Dig Safe Requests	1-800-962-7692 or 811 Dig Safely NY	1-888-DIGSAFE (1-888-344-7233) or 811 Dig Safe System Inc.
	811 is the nationwide number; see http://call811.com/Default.aspx	
Hazard Identification Hotline When working near power lines or high voltage lines	1-800-642-4272	1-888-625-3723

Also, visit <https://www.nationalgridus.com> for this and other National Grid information.

Specifications for Electrical Installations

2025

Covering National Grid's Service Areas in
Massachusetts (MA) and New York (NY)

Electric System Bulletin (ESB) 750

PREFACE

These 2025 specifications consolidate and replace the “Specification for Electrical Installation 2024, and are in effect for the following National Grid companies:

- Massachusetts Electric Company
- Nantucket Electric Company
- Niagara Mohawk Power Corporation

These specifications, which protect the mutual interests of the Customer and Company, may be revised or amended from time to time in keeping with developments and progress of the industry. For the latest official version of this document please visit the Company’s web site address at: <https://gridforce.my.site.com/electric/s/article/Electric-Specifications>.

Printed copies of these specifications are not document controlled and may be obtained from the Company by contacting the applicable Company representative. Therefore, the online version will always prevail over any uncontrolled printed documents. The 2025 version incorporates the ESB 750 Series Errata and Revisions issued in January 2024.

Where referenced in tariffs by the National Grid companies, this new edition is synonymous with the designations as “ESB 750 Book” or “Information and Requirements Book” and meets the same requirements.

TABLE OF CONTENTS

PREFACE	1
PROCESS AND INFORMATION.....	8
SAFETY INFORMATION.....	9
PART A – GENERAL INFORMATION.....	10
1.0 INTRODUCTION.....	10
1.1 Purpose	10
1.2 Scope	10
1.3 Rate Schedule	10
1.4 Cooperation and Time Requirements.....	10
1.5 Codes, Standards, and References	10
1.5.1 References	11
1.5.2 Supplemental Company Specifications.....	12
1.6 Requests for Information	12
1.7 Customer’s Responsibility	12
1.7.1 All Customers.....	12
1.7.2 Customers Served at Voltages Above 600V	13
1.8 Company’s Responsibilities.....	13
1.9 Inspection, Wiring Adequacy, And Enforcement	13
1.10 Disclaimer.....	14
1.10.1 Company Approval.....	14
1.10.2 Use of Electricity.....	14
1.10.3 Condition of Service	14
1.10.4 Company Warranty Statement.....	14
1.11 Enforcement of Company Requirements	15
1.11.1 Enforcement Criteria	15
1.11.2 Diversion of Electrical Energy	15
1.11.3 Unauthorized Attachment.....	15
2.0 DEFINITIONS	15
3.0 GENERAL SERVICE CONNECTION REQUIREMENTS	21
3.1 Application for Service.....	21
3.1.1 Application.....	21
3.1.2 Public Grants and Special Permits.....	21
3.1.3 Easements	21
3.1.4 One-Line Requirements	21
3.2 Number of Services	22
3.2.1 With Respect to Building and Premise.....	22
3.2.2 Electricity Delivered Through More Than One Meter.....	22
3.2.3 Multiple Service Requests.....	23

3.3	Temporary Service	23
3.3.1	Company Facilities	23
3.3.2	Location.....	23
3.3.3	Equipment	23
3.3.4	Duration.....	24
3.3.5	Cost.....	24
3.4	Access	24
3.5	Identification of Employees.....	24
3.6	Character of Service.....	24
3.7	Voltages Available	24
3.7.1	Available Services	24
3.7.2	New Customers (Applicants).....	26
3.7.3	Existing Customers	26
3.8	Services No Longer Standard	26
3.9	Load Balance.....	27
3.10	Increase in Service	27
3.11	Service Entrance Upgrade	27
3.12	Discontinuance of Service	27
3.13	Energy Management System	27
3.14	Electric Vehicle Charging	27
PART B – ELECTRIC SERVICE REQUIREMENTS		28
4.0	SERVICE CONNECTIONS.....	28
4.1	General.....	28
4.1.1	Rights-of-Way, Easements.....	28
4.1.2	Number, Routing and Location of Service Laterals or Service Lines	28
4.1.3	Relocation of Services.....	29
4.1.4	Voltage Drop Considerations	29
4.1.5	Minimum Size Single-Phase Service Connections	29
4.1.6	Service Conductor Splicing	29
4.1.7	Routing of Metered and Unmetered Conductors Within a Building.....	30
4.1.8	Temporary Service	30
4.1.9	Service to Manufactured and Mobile Homes, Mobile Home Parks, and Recreational Vehicle Parks	30
4.2	Overhead Secondary Voltage Service Connection (Under 600V).....	31
4.2.1	General.....	31
4.2.2	Service Attachment, Location.....	31
4.2.3	Customer-Owned Service Pole	32
4.2.4	Overhead Service Line Clearances.....	32
4.2.5	Service Drop and Connection to Service Conductors	35

4.2.6	Residential Overhead Service Upgrade	36
4.3	Overhead Primary Voltage Service Connection (2.4kV to 46kV inclusive)	36
4.4	Overhead Transmission Voltage Service Connection	36
4.5	Underground Secondary Service Voltage Connection (Under 600V)	37
4.5.1	General.....	37
4.5.2	Facilities in Shared Trench.....	37
4.5.3	Conduit System.....	37
4.5.4	Underground Secondary Service Connection from the Company's Overhead Distribution Supply Line	38
4.5.5	Underground Secondary Service Connection from the Company's Underground Supply Lines	38
4.5.6	Underground Residential Distribution (URD) Areas	39
4.5.7	Underground Secondary Service Connection	40
4.6	Underground Primary Voltage Service Connection (from 2.4kV to 46kV inclusive)	41
4.7	Underground Transmission Voltage Service Connection.....	41
4.8	Access Roads.....	41
4.9	Labeling Specification.....	41
5.0	SERVICE EQUIPMENT	41
5.1	General.....	41
5.1.1	Service Equipment Required.....	42
5.1.2	Service Equipment Minimum Continuous Current Rating	42
5.1.3	Service Equipment Minimum Short Circuit Withstand Capability	42
5.1.4	Routing of Metered and Unmetered Conductors.....	42
5.1.5	Taps Ahead of Main Service Equipment	42
5.1.6	When Service Equipment Ahead of Metering is Required (Cold Sequence)	42
5.1.7	Service Equipment on Service Poles, Pedestals, or Posts	42
5.1.8	Service Equipment Arrangement	43
5.1.9	Service Equipment Minimum Attributes	43
5.1.10	Instrumentation and Control Wiring.....	44
5.2	Residential.....	44
5.3	Network Service	44
5.3.1	General.....	44
5.4	Multiple Occupancy Building Service	44
5.5	Service Equipment Above 600V.....	44
6.0	GROUNDING.....	44
6.1	General.....	44
6.2	Equipment to Be Grounded or Bonded	44
6.3	Grounding and Bonding Methods.....	45
6.4	Grounding Restrictions	45

6.5	Ground Fault Protection	45
7.0	METERING	45
7.1	General.....	45
7.1.1	Meter Location and Access for New or Upgraded Services.....	46
7.1.2	Working Clearances.....	46
7.1.3	Physical Protection.....	47
7.1.4	Violations.....	47
7.1.5	Security of Unmetered Wiring	47
7.1.6	Taps Ahead of Metering	47
7.1.7	Group Metering	47
7.1.8	Shared Metering (for NY only).....	48
7.2	Meter Applications and Requirements 600V and Less.....	48
7.3	Self-Contained Meter Socket Installations.....	52
7.4	Transformer-Rated Metering 600 V and Less, 400 A and Above.....	53
7.4.1	Instrument Transformers and Enclosures	53
7.4.2	Meter Socket Enclosure	53
7.4.3	Sequence for Transformer-Rated Metering.....	53
7.4.4	Instrument Transformer Secondaries.....	53
7.4.5	Pad-mounted Transformer Service Metering	54
7.4.6	Metal-Enclosed Free-Standing Service Cubicles Rated 600 V or Less (Secondary Voltage Installations)	54
7.5	Metering Above 600 V	55
7.6	Metering Pulse Signals.....	55
7.7	Meter Boards and Supports.....	55
7.7.1	Meter Mounting	55
7.7.2	Meter Mounted on the Exterior of a Building	55
7.7.3	Meter Mounted on a Free-Standing Support.....	55
7.7.4	Meter Installed Interior to a Building.....	56
8.0	MOTORS	56
8.1	General.....	56
8.2	Single-Phase Motors	56
8.2.1	Single-Phase Motor Limitations.....	56
8.2.2	Maximum Locked-Rotor Currents	57
8.2.3	Single-Phase Motors on Three-Phase Service	57
8.3	Three-Phase Motors.....	57
8.3.1	Size of Motors	57
8.3.2	Maximum Locked-Rotor Currents	57
8.3.3	Maximum Permitted Starting Current.....	58
8.4	Motor Protection	58

8.4.1	Overload Protection.....	58
8.4.2	Protection Against Single-Phase Operation.....	58
8.4.3	Reverse Phase Protection.....	58
8.4.4	Undervoltage Protection.....	58
8.5	Motor-Starting Requirements.....	59
8.5.1	Objectionable Voltage Variation.....	59
8.5.2	Current Inrush Limitation.....	59
8.5.3	Favorable Locations.....	59
8.5.4	Company Notification of 3 HP Single-Phase and 10 HP Three-Phase Applications.....	59
9.0	TRANSFORMER INSTALLATIONS ON CUSTOMER PREMISES.....	60
9.1	General.....	60
9.2	Installations.....	60
9.2.1	Overhead Transformers.....	60
9.2.2	Outdoor Single-Phase Pad Mounted Transformer.....	60
9.2.3	Outdoor Three-Phase Pad Mounted Transformer.....	60
9.2.4	Transformer Vault in Non-Network Area.....	60
9.2.5	Mat and Fence Substation.....	61
9.3	Available Fault Current.....	61
9.3.1	Network Services.....	61
9.3.2	Single-Phase Transformers.....	61
9.3.3	Three-Phase Overhead Transformers.....	62
9.3.4	Three-Phase Pad Mounted Transformers.....	62
10.0	DISTURBANCES AND POWER QUALITY.....	63
10.1	General.....	63
10.2	Motors.....	63
10.3	Devices with Intermittent High Current.....	63
10.4	Automatic Reclosing.....	63
10.5	Harmonic and Other Distortion.....	63
10.6	Power Supply to Voltage Sensitive Equipment Computers and Sensitive Equipment.....	64
10.7	Isolation Transformer.....	64
10.8	Electric Vehicle (EV) Chargers.....	64
11.0	CUSTOMER-OWNED ELECTRIC SOURCES – INCLUDING STANDBY GENERATORS.....	64
11.1	General.....	64
11.2	Emergency and Standby Electric Sources.....	65
11.2.1	Compliance Criteria.....	65
11.2.2	Electric Source Type & Installation Method.....	65
11.2.3	Transfer Systems.....	66
11.2.4	Identification and Clearances.....	67
11.3	Parallel Electric Power Production.....	67

11.3.1	Inverters	67
12.0	UTILIZATION and SPECIAL EQUIPMENT.....	67
12.1	Electric Fences.....	67
12.2	Signs and Automatically Controlled Lighting.....	68
12.3	Lightning and Surge Protection	68
12.4	Power Factor Correction, Capacitors	68
12.4.1	Capacitor Installation.....	68
12.4.2	Static VAR Compensators (SVC).....	68
12.5	Radio and Television.....	68
12.5.1	Transmitting Station, Repeater, or High Frequency Equipment.....	68
12.5.2	Antennas	68
12.5.3	Eliminator or Trap.....	69
12.6	Carrier Current Systems.....	69
13.0	REVISION HISTORY.....	69
14.0	FIGURES	70
Part C	– APPENDICES.....	106
	APPENDIX 1 - OVERHEAD ATTACHMENT METHODS	106
	APPENDIX 2 - TRAFFIC CONTROL METERED SERVICE REQUIREMENTS.....	108
	APPENDIX 3 - SWIMMING POOL CLEARANCE CRITERIA	110
	APPENDIX 4 - ELECTRIC SERVICE AREAS	113
	CHANGE PROPOSAL FOR NATIONAL GRID.....	121

PROCESS AND INFORMATION

Obtaining Electric Service

Please refer to the inside front cover of this book for Company contact information by phone, facsimile, mail, email, or internet.

Applicants requesting new electric service, existing customers requesting an upgrade or relocation of their electric service or new temporary service shall:

- ✓ Contact the state-specific Customer Service Center and speak with a Service Representative.

SAFETY INFORMATION

National Grid is committed to the pursuit of safety excellence through compliance with all OSHA, State, and Regulatory requirements. We encourage the Customer or its Contractor to comply with the same requirements and for safe trenching.



811 is the nationwide number for utility locate requests before trenching, also:

<http://www.call811.com>



For Utility Locate Requests in New England States:

- Call 1-888-DIGSAFE (344-7233) or 811
- Submit Online: <http://www.digsafe.com>



For Utility Locate Requests in New York:

- Call 1-800-962-7962 or 811
- Submit Online: <https://udigny.org/>



The Electrical Safety Foundation International (ESFI): <http://www.esfi.org>

For worker safety precautions as applicable for the installation, please refer to:

- NESC ANSI C2;
- NFPA 70E;
- OSHA and
- any other state and local requirements.

PART A – GENERAL INFORMATION

Note: The information provided in Part A contains common general conditions of electric service based upon state laws and regulations that govern the authority of utilities to provide electric service under applicable tariffs. While each utility's requirements may vary from state-to-state, most states have adopted some form of the National Electrical Safety Code (NESC). The NESC is an adoptable code promulgated by IEEE through the ANSI standards-making process.

1.0 INTRODUCTION

1.1 Purpose

The purpose of this document is to provide National Grid's general electric service rules for basic requirements essential for maintaining satisfactory service or interconnection compatibility with National Grid's electric power system (EPS). In addition, these rules are intended to properly protect the safety and interests of National Grid's Customers and others served by the EPS operated by the utility. Where the term "Company" is used, it refers to the applicable serving utility within National Grid's service territories. These basic rules are supplemented by the applicable tariffs in effect in each of the Company's service territories; as such tariffs may be amended from time to time.

1.2 Scope

These electric service requirements cover conductors and equipment connecting the Company's EPS at the Customer's service point. These also include other topics associated with the supply of electricity that are of mutual interest to the Company, Customers, design professionals, and qualified installers. It should be noted that this is not intended to be a complete set of rules governing the electrical premises wiring and equipment.

1.3 Rate Schedule

Electric tariffs and associated rules and regulations are on file with the applicable state regulatory agencies and are also available for download from the Company's website for each state. The following are the associated National Grid tariffs for these specifications, as such tariffs may be amended from time to time:

- In Massachusetts, "Terms and Conditions for Distribution Service"
- In New York, P.S.C. No. 220, "Schedule for Electric Service"

1.4 Cooperation and Time Requirements

The Customer, its authorized agent and/or design professional is responsible for cooperating with the Company and permitting a thorough and proper technical review by the Company for acceptance and timely delivery of the Company's services. Preliminary information leading to new or increased electric service requirements shall be submitted to the Company early in the planning stages. This will ensure proper design and scheduling coordination of the work associated with the service connection.

1.5 Codes, Standards, and References

These rules supplement and may exceed standards of safety regarding the Customer's electrical installation set forth in the National Electrical Code (NEC), the National Electrical Safety Code (NESC) and other applicable codes. These rules are not a substitute for the NEC, NESC, municipal codes, or any other authority having jurisdiction.

The Company requires that the Customer's premises wiring installations be made in accordance with all applicable codes and these rules. Service shall be denied if these codes and the Company's rules are not met. The Company accepts no liability for direct or indirect damages resulting from the Company's refusal to energize a service or the Company's termination of a service that does not meet these rules and all other applicable codes.

[Figure 1.5-1](#) is a general illustration of where the Company’s electric supply and the Customer’s premises wiring meet for what is covered and what is not covered by the NEC as described in NEC Section 90.2. Local conditions of service may permit the Company’s metering to be installed at any point on either side of the service point; see 90.2(B)(5) in the NEC. Conditions of electric service are based on governmental laws or regulations that determine the Company’s authority to provide electric service under their tariffs. These conditions of electric service affect the location of the service point and facilities under the Company’s exclusive control.

1.5.1 References

NFPA 70	National Electrical Code
NFPA 70B	Recommended Practice for Electrical Equipment Maintenance
NFPA 70E	Standard for Electrical Safety in the Workplace
ANSI/IEEE C2	National Electrical Safety Code
Building Code	States of MA and NY
<hr/>	
UL 2594	Electric Vehicle Supply Equipment
UL 2202	DC Charging Equipment for Electric Vehicles
UL 9741	Electric Vehicle Power Export Equipment
UL 1741	Inverters, Converters, Controllers and Interconnection System Equipment for Use with Distributed Energy Resources
<hr/>	
Massachusetts General Laws:	Chapter 82, Section 40A Chapter 164, Section 127 & 127A Chapter 166, Sections 21A-21G Chapter 266, Section 30 Chapter 266, Section 127
New York State Laws:	Public Service Law, Chapter 48 of the Consolidated Laws High Voltage Proximity Act, contained in Labor Law, Chapter 31 of the Consolidated Laws, Section 202-h 16 NYCRR, Rules and Regulations of the Department of Public Service
<hr/>	
Federal Occupational Safety and Health Administration (OSHA)	29 CFR 1926.550(a)(15) 29 CFR 1926.651 (b)(1)(2) 29 CFR 1910.333 (c)
Excavation Notification Requirements - Dig Safe	In MA: 1-888-DIGSAFE (344-7233) In NY: 1-800-962-7962 811 is the nationwide number; see https://call811.com/811-In-Your-State

1.5.2 Supplemental Company Specifications

Note: ESB's designated with an asterisk (*) are applicable only in New York Specifications for Electrical Installations and Supplements Errata and Revisions

ESB No. 751*	General Requirements Above 600V Service
ESB 751-NYPR*	NY Protection Requirements
ESB No. 752*	Service above 15,000V
ESB No. 753*	Primary Meter Pole
ESB No. 755*	Operation & Maintenance Requirements for Service Above 600V
ESB No. 756	General Requirements for Parallel Generation Connected to a National Grid Owned EPS
- Appendix A	Connected to National Grid Facilities in New York, Massachusetts, New Hampshire, and Vermont Not Applicable to State Regulatory or Regional ISO Generator Interconnection Requirements
- Appendix B	Requirements for DG Connected to National Grid's Radial Distribution per the NYS SIR
- Appendix C	Requirements for Parallel Generation Connected to National Grid Facilities in Massachusetts
ESB No. 757	Network Services
ESB No. 758*	Primary Service to Metal Enclosed Gear
ESB No. 759A	Underground Residential Distribution (URD) Installation and Responsibility Guide
ESB No. 759B	Underground Commercial Distribution (UCD) Installation and Responsibility Guide

See these Electric System Bulletins at:

<https://gridforce.my.site.com/electric/s/article/Electric-Specifications>.

1.6 Requests for Information

The Company invites inquiries and will assist the Customer with the application of these rules. Refer to the [Process and Information](#) section in the beginning of this book.

1.7 Customer's Responsibility

1.7.1 All Customers

The Customer shall provide the service entrance, in accordance with the Company's requirements, and all premises wiring on the load side of the service point. At all times, the Customer is responsible for ensuring that its electrical interconnection facilities attached to the Company's EPS are designed, installed, operated, and maintained in accordance with all applicable codes, standards, rules, regulations, statutes, governmental ordinances, and third-party permits (collectively referred to as all applicable requirements). The Customer is responsible for contacting all third parties and obtaining all applicable permits (including environmental if required), approvals and inspections, and underground facility locating services for its premises wiring installation. Documentation substantiating the completion of such activities shall be furnished to the Company upon request.

The Customer shall assume or delegate, to an authorized representative, the primary responsibility for approval and acceptance of its equipment and the timing of its installation. The Company cannot accept any responsibility for the condition of the Customer's premises wiring and equipment. The Customer is

responsible for the cost of on-going compliance with all applicable requirements noted above as well as any and all system design and operating changes to its installation.

1.7.2 Customers Served at Voltages Above 600V

1.7.2.1 Design Acceptance

The planning and design of electric service equipment at voltages above 600V requires skilled application of engineering principles and data to ensure proper interconnection and functionality with the utility electric supply system. Therefore, a Professional Engineer, licensed in the state where service is made, shall prepare all documents submitted to the Company in connection with all electric service equipment above 600V. (Reference ESB 751 for details.)

1.7.2.2 Operation and Maintenance

Customers owning electric service equipment above 600V shall operate and maintain such equipment in accordance with Company supplied operating instructions and specifically ESB 755, "Operation and Maintenance Requirements for Services above 600V."

1.7.2.3 Company Device Operating Nomenclature

If applicable, National Grid will provide operating device numbers for customer service equipment. This equipment may be, but not limited to, switches, circuit breakers, primary fuses or secondary fuses. These device numbers provide for clear communication about equipment between the Company system operator and the Customer service equipment operator. These device numbers shall be shown on any drawing referencing this equipment and match the labels in the field. Reference [Section 4.9](#) for label specifications.

1.8 Company's Responsibilities

The electric supply and service installation provisions and costs shall be in accordance with the Company's filed tariffs.

These specifications are subject to revision without notice. They may be revised or amended as the Company shall determine, or as required by developments of the industry to protect the mutual interests of the Customer and Company. The latest revision shall be used. Additional copies of these specifications and any errata can be obtained from the Company; also see [Section 1.5.2](#) for Company supplemental specifications.

1.9 Inspection, Wiring Adequacy, And Enforcement

The Company requires the Customer to furnish satisfactory evidence of the safe condition of its wiring before any service is connected. This will be in the form of an electrical inspection approval certificate from the authority having jurisdiction (AHJ) or an inspection agency approved by the AHJ and the Company. Inspections shall confirm compliance with the National Electrical Code, any applicable municipal codes, and any specific utility service rules that are in addition to the aforementioned codes. The Company and its accepted inspection organizations have the authority for enforcement of these rules. An inspection approval sticker shall be placed on the right side of the meter socket enclosure to assure compliance.

The Company requires certificates of inspection:

- (A) On all new services, and
- (B) To re-energize any existing service that has been de-energized by any disconnect method (cutting service drop or lateral conductors at pole or weatherhead, or padmount transformer, meter removal, etc.) for any of the reasons or durations listed below:
 - (1) An emergency as a result of accidental damage, fire, flood, weather, or earth related catastrophes.
 - (2) Theft of service.

- (3) De-energization of service duration exceeding twelve months.
- (4) Following 36 months of service inactivity.
- (5) Anytime the Company severs electric service for the purpose of the premise wiring system being replaced, altered or extended beyond the service point up to and including the service equipment.
- (6) Unsafe condition by any AHJ mandate or by the Company. Examples of unsafe conditions include, but are not limited to, those listed below.
 - (a) Frayed, split or damaged service entrance cable jacket
 - (b) Corroded or exposed conductors
 - (c) Damaged meter socket enclosure or service equipment
 - (d) Loose or detached point of attachment
- (7) Anytime the company discovers evidence of premise wiring modifications

1.10 Disclaimer

1.10.1 Company Approval

The Company's approval of the Customer's installation constitutes the Company's acceptance of the Customer's proposed arrangement and equipment as meeting the Company's minimum requirements under these rules and does not relieve the Customer from the obligation of complying with all applicable codes, statutes, rules or regulations.

1.10.2 Use of Electricity

Unless otherwise specified in the applicable regulatory tariff, the Company shall not be liable for damage to the person or property of the Customer or any other persons resulting from the use of electricity or the presence of the Company's equipment on the Customer's premises.

Relative to any information supplied by the Company in connection with a Customer, it must be understood that the Company's EPS is a dynamic system that changes from moment to moment as operating demands are made to the system. Furthermore, permanent changes to the system are common which will change the information provided to Customers or their Agents. Although the Company makes every reasonable effort to obtain reliable information and proper calculations, the Company provides no warranty, expressed or implied, as to the accuracy, reliability or completeness of data furnished to Customers or their Agents. National Grid reserves the right to make improvements, upgrades or other changes to the electric system without notice. Such changes may invalidate any information provided.

1.10.3 Condition of Service

The Company shall not be liable for, or in any way in respect of, any interruption, abnormal voltage, discontinuance, or reversal of its service, due to causes beyond its immediate control whether accident, labor difficulties, condition of fuel supply, the decision of any public authority, or failure to receive any electricity for which in any manner it has contracted, or due to the operation in accordance with good utility practice of any emergency load reduction program by the Company or one with whom it has contracted for a supply of electricity, or inability for any other reason to maintain uninterrupted and continuous service; provided, however, that under the terms of the Company's applicable tariff if the Company is unable for any of the causes enumerated above to supply electricity for a continuous period of two (2) days or more, then upon request of the Customer, the Demand Charge, if any, shall be suspended for the duration of such inability.

1.10.4 Company Warranty Statement

For all voltages and services, the Company will cooperate with its Customers or their representatives. However, neither by inspection, nor by the rendering of advisory service, nor in any other way, does the

Company give any warranty, expressed or implied, as to the adequacy, safety, or other characteristics of any equipment, wires, appliances, or devices owned, used, or maintained by Customers.

1.11 Enforcement of Company Requirements

1.11.1 Enforcement Criteria

The Company, the AHJ, and their accepted inspection organization have the authority for enforcement of the Company specifications. The Company's Specifications for Electrical Installations Committee has the responsibility for: making interpretations of the rules, deciding upon the approval* of equipment and materials, and granting the special permissions contemplated in a number of the rules.

Alternative construction methods not covered in these specifications must be submitted to the Company in writing and be approved* by the Company prior to purchase and/or installation of equipment. The Company shall only grant deviations from these specifications in writing.

Exceptions from the NEC or other codes shall only be granted in writing by the local code authority exercising jurisdiction and filed with the Company.

***Note:** See [Section 2.0](#) for the definition of the term "Company Approval". The Company does not "approve" all aspects of the Customer's equipment or premises wiring installation.

1.11.2 Diversion of Electrical Energy

A diversion of electrical energy is any method or device used by any person that prevents an electric meter from duly registering the quantity of electrical energy supplied by the Company and/or the taking of any electrical current without the Company's consent.

Where there is evidence of meter tampering or theft of electrical energy, the responsible person or persons shall be liable for prosecution under penalty of law.

1.11.3 Unauthorized Attachment

The Company forbids any unauthorized attachments to its poles and towers, such as banners, signs, clothes lines, antennas, basketball hoops, lighting fixtures, etc. It forbids the use of any of its facilities for placards or other advertising materials. The Company will remove any such unauthorized attachments without notice and may prosecute such trespassing.

The Company forbids any work by contractors on or in any of its facilities without prior written authorization by the Company.

The attachment of antenna systems to Customer-owned electric service masts or poles carrying the Company's conductors is strictly prohibited due to the possibility of serious results from accidental contacts. Such attachments will be removed immediately upon discovery by the Company, and the removal will be at the Customer's expense.

2.0 DEFINITIONS

Notes:

1. The following are terms defined as used in this publication.
2. For graphical relationship of defined components and section references in this book, see [Figure 2-1](#).

Applicant: Any entity (individual, firm, partnership, corporation, association, municipality, or governmental body) requesting a new service from the Company for their own use and not for resale or delivery to others.

Note: The Company must be consulted for specific Applicant rules as they apply in the Company's applicable tariff.

Area Lighting (Utility): A utility lighting distribution system that provides lumens on public or private property. (See NEC 90.2(A) where area lighting is not under the exclusive control of utilities and see the NESC for information that covers area lighting under the exclusive control of utilities.)

Authority Having Jurisdiction (AHJ): An organization, office, or individual responsible for enforcing requirements of a code or standard, or for approving equipment, materials, an installation, or a procedure. (See also NEC Article 100.)

Back-up Service: A service type provided during an unscheduled outage of the Customer’s facility.

Building: A structure which stands alone or which is cut off from adjoining structures by approved fire walls with all openings therein protected by approved fire doors.

Clearance: Required separation mandated by codes or the Company.

Closed Transition Transfer: A “make-before-break” transfer of electrical power sources which makes momentary contact with both synchronized power sources before it breaks contact with one of the two sources. It allows momentary paralleling of the generator and utility system under specific conditions. One example is a closed transition automatic transfer switch (ATS).

Cold Sequence Metering: Metering equipment located on the Customer’s side of the service equipment. (See definition for service equipment.)

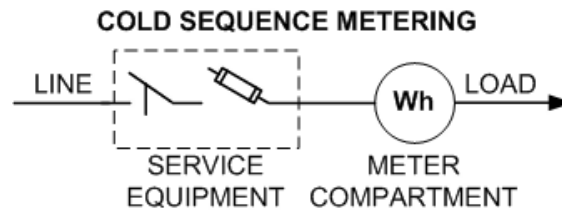

Company: The electric utility companies doing business as National Grid to which these requirements apply are:

- Massachusetts Electric Company
- Nantucket Electric Company
- Niagara Mohawk Power Corporation

Company Approval: Acceptance for the minimum requirements of National Grid exclusive of the Customer’s obligation of complying with all applicable codes, statutes, rules or regulations. (See [Section 1.10.1](#))

Customer: An existing user of recurring electric service. (A contractor or developer performing work on behalf of a Customer is considered an agent of the Customer.)

Seasonal Customer: A Customer who applied for and receives the Company’s service periodically each year, intermittently during the year, or at other irregular intervals.

Design Professional: A Professional Engineer (PE) licensed to practice in the state where service is being installed and who is directly retained by the Customer for that purpose. (If the state licensed PE is representing a multi-member design firm, the firm shall have state certification to practice professional engineering and a copy of such license must be provided to the Company upon request. Any Company requested design professional certification proof must be submitted to the Company in writing upon initial design submission.)

Distribution Line: A distribution line is an electric line, either overhead or underground, including the necessary and ancillary accessories to distribute electric energy, which may provide service to more than one Customer. A distribution line may be located (1) in a street, highway, alley, or (2) on private right-of-way when used or useful to supply two or more Customers at separate premises.

Drip Loop: Individual conductors formed to prevent the entrance of moisture, and which provide adequate length to meet the Company's and applicable code requirements.

Electrical Inspector: Inspectors external to the Company who are approved by the municipality in which they are working and recognized by the Company. Electrical Inspectors are responsible for ensuring that the installation complies with all applicable codes and Company requirements, service equipment, material, installations, and/or procedures.

Electric Service: Maintenance by the Company of the appropriate voltage and frequency at the point of delivery shall constitute the delivery of electric service to the Customer. (See definition for Service.)

Electric System Bulletin (ESB): The Company's specifications for electrical installations which provide technical guidance to applicants and customers and their electrical consultants/contractors for their installation of electrical equipment of interest to the Company. These bulletins include ESB 750-series Errata and Revisions, ESB 750 and supplemental specifications ESB's 751, 751-NPYR, 752, 753, 754, 755, 756, 757, 758, 759A and 759B.

Emergency: An unplanned, natural or accidental event that affects existing electric service.

Electric Power System (EPS): Company EPS refers to the electric power system owned, controlled, or operated by the Company and used to provide transmission or distribution services to its customers. Also referred to Company's system.

Electric Vehicle Supply Equipment (EVSE): Device that connects to the Company EPS and provides energy to a Plug-in Electric Vehicle.

Energy Management System (EMS): As defined by NEC Article 750, A system consisting of any of the following: a monitor(s), communications equipment, a controller(s), a timer(s), or other device(s) that monitors and/or controls an electrical load or a power production or storage source.

Exclusive Control: Generally, covers installation, ownership, restricted access, operation, and maintenance by qualified and authorized persons.

Good Utility Practice: As defined by the NY and MA tariffs.

Hot Sequence Metering: Metering equipment located on the Company's side of the service equipment. (See definition for Service Equipment.)

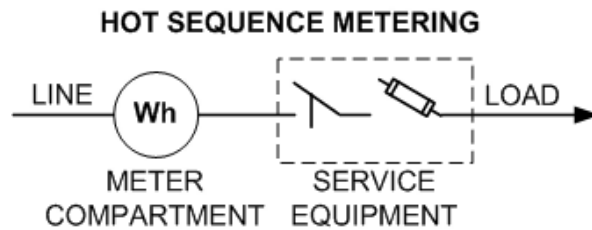

Life Safety System: Those Life Safety Systems legally required by local, municipal, state, federal, or other codes or jurisdictions which may include, but not be limited to fire pumps, that are tapped ahead of the main service equipment and require utility metering.

Line: A system of poles, conduit, wires, cables, transformers, fixtures and accessory equipment used for the distribution of electricity to the public. A line may be located: (1) in a street, highway, alley; or (2) on a private right-of-way when used or useful to supply two or more Customers at separate premises.

Manufactured Home: A factory assembled structure or structures transportable and designed to be used as a dwelling unit with a permanent foundation acceptable to the local AHJ.

Mobile Home: A factory assembled structure or structures transportable on their own running gear and designed to be used as a dwelling unit(s) without a permanent foundation.

Multiple Occupancy Building: A structure, including but not limited to row houses, town houses, condominiums, apartment buildings, commercial and mixed-use buildings, and is designed to contain

three or more individual dwelling units for permanent residential occupancy and/or for commercial purposes.

Open Transition Transfer: A “break-before-make” transfer of electrical power sources which breaks contact with one source of power before it makes contact with another. It prevents backfeeding from a generator into the utility line. One example is an open transition automatic transfer switch (ATS).

Plug-in Electric Vehicle (PEV): A vehicle that plugs into Electric Vehicle Supply Equipment to exchange electrical energy.

Point of Attachment: The location of the service drop conductors to a building or structure provided by the Customer and installed to maintain clearances specified by the NEC (Article 230) and by the Company’s requirements. (Service conductors are supported by mechanical attachment to the building or structure.)

Premise: A premise is a unified, undivided parcel of real property under the Customer or Applicant’s control through ownership or lease which is not separated by a public road, right of way, or property belonging to another entity. A premise may or may not contain buildings or structures within the real property.

Premises: The land and buildings of the Customer located on the Customer’s side of the service point.

Primary: The Company’s distribution systems typically operating over 600V.

Qualified [Person/Installer/Electrical Contractor]: One who has skills and knowledge related to the construction and operation of the electrical equipment and installations and has received safety training to recognize and avoid the hazards involved.

Recreational Park: An area primarily, intended for recreation that may contain campgrounds, recreational vehicle sites, modern facilities (cottages), beaches, boat launches, picnic areas, hiking, and other utilities used in modern recreational camping. These areas are used on an intermittent, temporary, seasonal, or irregular basis.

Recreational Vehicle: A vehicular type unit primarily designed as temporary living quarters for recreational, camping, or travel use, which either has its own motive power or is mounted on or drawn by another vehicle. These include: travel trailer, camping trailer, truck camper, and motor home.

Recreational Vehicle Park: An accommodation for Recreational Vehicles where individual site occupancy is normally of short duration.

Restricted Access by the Company: Areas where exclusive control by the Company is maintained.

Riser (aka riser pole, siphon): A structure which accommodates the transition of overhead conductors to underground conductors and vice versa.

Secondary: The Company’s distribution systems typically operating at 600V or below.

Separately Derived System: A premises wiring system whose power is derived from another source of electricity and that has no direct electrical connection, including a solidly connected grounded circuit conductor, to the service.

Service: The conductors and equipment for delivering energy from the Company's distribution line to the wiring system of the Customer served. (See definition for Electric Service.)

Residential Service: Service to one or more dwelling unit(s) providing complete and independent living facilities for one or more persons and which include permanent provisions for sleeping, cooking, and sanitation.

Non-Residential Service: All service types other than residential.

Service Conductors: The conductors from the service point to the service equipment of the Customer supplied by the Company.

Overhead Service Conductors: The overhead conductors between the service point and the first point of connection to the service-entrance conductors at the building or other structure.

Underground Service Conductors: The underground conductors between the service point and the first point of connection to the service-entrance conductors in a terminal box, meter, or other enclosure, inside or outside the building wall. (Where there is no terminal box, meter, or other enclosure, the point of connection is considered to be the point of entrance of the service conductors into the building. Underground service conductors are not supplied by the Company.)

Service Connection: One service lateral or service line and its associated service entrance.

Service Drop: The overhead conductors between the last pole or other aerial support of the Company's electric supply line up to and including the splices connecting to the service point's service entrance conductors at the building or other structure.

Service Entrance: That part of the Customer's wiring from the point of attachment or termination of the service lateral or service line to and including the service equipment.

Service Entrance Conductors: The wires or cables between the service conductors and the service equipment.

Overhead System Service Entrance Conductors: The service conductors between the terminals of the service equipment and a point usually outside the building, clear of building walls, where joined by tap or splice to the service drop or overhead service conductors.

Underground System Service Entrance Conductors: The service conductors between the terminals of the service equipment and the point of connection to the service lateral or underground service conductors. (Where service equipment is located outside the building walls, there may be no service-entrance conductors or they may be entirely outside the building.)

Service Equipment: The Customer's necessary disconnecting and protective equipment intended to constitute the main control and cutoff of the supply from the service point. This consists of a circuit breaker(s) or switch(es) and fuse(s) and their accessories connected to the load end of service conductors. The service overcurrent device shall be an integral part of the service disconnecting means or shall be located immediately adjacent thereto.

Service Head (Weatherhead): For cable in conduit risers or Type SE cable, a service head is a listed device that is raintight for the purpose of preventing water from entering service entrance conductors, raceway, or equipment.

Service Line or Lateral: The Company's electric line including the necessary and ancillary accessories to connect a distribution line to an individual Customer's meter or point of attachment. (A service line or service lateral, at the Company's discretion, may be connected to two or more meters at a single premise. Wiring along the outside of the Customer's house or building shall not be included in the service line or service lateral.)

Service Line: The overhead conductors between the utility electric supply system and the service point. (A service line does include a service drop.)

Service Lateral: The underground conductors between the utility electric supply system and the service point.

Service Point: The point of connection between the facilities of the Company and the Customer's premises wiring. (The service point can be described as the point of demarcation between where the serving utility ends and the premises wiring begins. The serving utility generally specifies the location of the service point based on their conditions of service. (Refer to Figure 1.5-1 and Figure 2-1.)

Service Riser Mast: A rigid metal conduit containing service entrance conductors that supports the service drop to maintain required vertical clearance.

Service Riser Pole: The Company's pole where the Customer's underground service conductors emerge to connect to the Company's overhead distribution line or transformer.

Short-term Service: A service that is recurrently required only for short periods each time, either periodically each year, intermittently during the year, or at other irregular intervals. (Typically used by seasonal Customer.)

Standby Power System: An alternate source of electricity incorporating necessary transfer equipment intended to supply power to selected loads upon loss of the normal power supply.

Stretch Code: A stretch code is a locally mandated code or alternative compliance path that is more aggressive than base code. An example of Stretch Code requirements may be pre-wiring for future electrification loads and DER.

Supply Point: The point of connection of the Company's service lateral or service line and the facilities of the Company.

Tariff: Document containing regulatory framework by which the Company administers fair and consistent handling of all applicants and customers within the Company's State-specific service territory.

Temporary Service: A non-recurring service intended to be used for a short time only, not to exceed one year for residential or two years for commercial applications. (Temporary service can be to a non-permanent structure or personal property, or to a building or structure which is non-permanent in that it may be readily removed or relocated, or as a preliminary connection toward the establishment of permanent service.)

Underground Commercial Distribution (UCD): An underground electrical supply system using at-grade transformers and switchgear to serve commercial or industrial Customers.

Underground Residential Distribution (URD): An underground electrical supply system using at-grade transformers and switchgear to serve five or more residential Customers.

Utilization Equipment: An electrical installation that uses electric or light energy for electronic, electromechanical, chemical, heating, lighting, testing, communication, signaling, or similar purposes on the premises wiring side of the service point. (Performed under the NEC.)

3.0 GENERAL SERVICE CONNECTION REQUIREMENTS

3.1 Application for Service

3.1.1 Application

Application for a new or changed service may ordinarily be made by mail, facsimile, telephone call to the Company, or by means of the Company's Web site (<https://www.nationalgridus.com>). Refer to the [Process and Information](#) section at the beginning of this book. Written application will be required when a service is taken from a line extension or when otherwise mandated by the provisions of the applicable tariff.

An applicant must make a separate application for each point of delivery and metering point, and for each class of service desired. That is, for each separate residence, apartment, business, building, structure, or premise where electric service is desired, a separate application is required. The Company will extend facilities to "premises" specifically identified on municipal tax maps.

Application should be made as far as possible in advance of the date the new or changed service is required to assure time for engineering, ordering of material, and construction. Delivery of equipment, depending on size and voltage rating, may take considerable time. A plot plan designating the location of buildings or additions should be provided with new electric load data.

3.1.2 Public Grants and Special Permits

In many cases, public grants or special permits must be obtained by the Company from the local governmental authority where it is required that a service be run over, under, or along a public way. In some instances, these grants and permits can be obtained only after public hearings are held. In such cases, delays in service connections can be avoided or curtailed by applying to the Company for service at the earliest possible date.

3.1.3 Easements

As a condition of service, the Applicant or Customer must provide the Company with an easement(s), properly executed by all owners of record drafted by the Company, for all Company owned facilities located on private property (to include User or Private Roads (NY) and Private Ways (MA)), whether or not such private property is owned by the Customer. The Applicant or Customer will provide such easement(s) prior to the start of the Company's construction and at no cost to the Company. The Applicant or Customer shall provide a copy of its mortgage and deed, together with a copy of the survey and/or plan of record, for the Company's use in preparation of the easement(s) as well as any other documents necessary for the Company to prepare such easement(s).

3.1.4 One-Line Requirements

Customers shall submit one-line diagrams per the following requirements (see ESB 756 for DER interconnection one-line requirements):

- (A) A one-line diagram shall be submitted for all single phase services 400A or greater, and for all three phase services 200A or greater.
- (B) One-line shall make use of [Figure 3](#) for electrical symbols, and IEEE C37.2 for relay device numbers.
- (C) When required, one-lines shall be stamped by a Design Professional. Stamp shall be dated, and the date must be after all changes are permanently affixed to the diagram.
 - (1) Professional Engineering Stamps are required when:
 - (a) Primary Voltage Service, see ESB 751, 752, 753, and 758.
 - (b) Customer elects to use an Energy Management System, excluding residential applications.
 - (c) Customer resides in a municipality where an Energy Stretch Code is enforced.

- (2) Stamps shall be required at:
 - (a) Time of application
 - (b) Final Company review and acceptance
 - (c) As-Built / Witness Test
- (D) One-line files submitted to the Company:
 - (1) Revision Block shall be up to date,
 - (2) Changes from previous revision shall be highlighted.
- (3) Shall use the File Naming Convention: WRxxxxxxxxx_Online_Revision#xx_(Date-Submitted)
- (E) One-line shall show:
 - (1) Number, size, and type of service conductors (See Section 4)
 - (2) Number, size, and material of conduits
 - (3) Service equipment (See Section 5)
 - (a) Breaker frame size and trip setting
 - (b) Fuse size and class
 - (4) Metering (See Section 7)
 - (a) Meter sequencing
 - (b) Number and size of self-contained metering, noting any meter with bypass handles
 - (c) Metering located in Company owned service transformers
 - (d) CT Cabinets, showing conductor number and size entering and leaving cabinet
 - (e) CT Compartments in customer owned switchgear shall require a set of switchgear shop drawings
- (F) Electric Vehicle Chargers:
 - (1) For EVSE, that are certified to UL 2594 or UL 2202 (i.e. charge only), this shall be stated on the one-line and tech sheets shall be provided to confirm this fact.
- (G) Energy Management Systems:
 - (1) For customers wishing to use an Energy Management System per NEC 750.30, the one-line shall state the failsafe operation per NEC 750.30(C)(2) and the Marking per NEC 750.30(C)(4).
- (H) Stretch Code
 - (1) For customers that reside in a municipality that elects to adhere to a State Energy Stretch Code (MGL 25A Section 6 for MA), the customer shall notate electrical assets, that are pre-wired for future electrification loads and not for initial use, as "Future Electrification Assets".

3.2 Number of Services

3.2.1 With Respect to Building and Premise

One alternating current service will normally be installed to a building or structure on a premise.

3.2.2 Electricity Delivered Through More Than One Meter

Where electricity is delivered through more than one meter, the cost of service delivered through each meter will be computed separately.

3.2.3 Multiple Service Requests

Multiple service requests, by their nature, often impose complex issues with respect to state laws and the Company's obligations. For these requests the concepts of premise, building, and necessity, need to be evaluated individually. These key considerations require a prospective Customer contemplating such a multiple service request to contact the Company prior to proceeding with either a formal electric service request or developing project plans assuming such an arrangement. Where multiple services are proposed for a single building or single structure, the local AHJ shall approve such arrangements, in writing, to ensure compliance with applicable Codes and to ensure personal safety and avoid property damage. The Company will furnish the necessary details for this approval to the Customer. Even if approved by the AHJ, the Company will make the final determination as to whether multiple services will be permitted.

When the above documentation has been received and the Company approves of a multiple electric service arrangement, the Company will provide specific requirements for each service point including but not limited to a single point of disconnect for the Company's primary voltage supply to that premise. Due to site specific challenges, the Company may limit the number of primary voltage supply points dedicated to a single premise. The Company recommends the Customer consult its building insurance carrier regarding the potential liabilities associated with specific multiple service point proposals.

In addition, as required by the Company's applicable tariff, the Customer shall reimburse the Company for any distribution facilities requested for the Customer's convenience that the Company deems to be over and beyond what is necessary in order to provide service to the Customer. The Company is under no obligation, however, to provide such facilities. Mutual agreement is required between the Customer and the Company. The Company will provide estimates for cost contributions required for providing additional service(s) in accordance with its applicable tariff. If a Customer desires more than one service, and could otherwise be supplied through the one service, and if the Company allows such additional service, the Customer shall pay the entire cost of installing the additional service according to the Company's applicable tariff.

The Customer shall provide the necessary provisions, space, clearances, and access for the required Company equipment. Required Company equipment can include but not be limited to multiple transformers, pad-mounted switches, and/or pole installations.

3.3 Temporary Service

3.3.1 Company Facilities

Temporary service facilities may include a line extension, a service lateral, installation of transformers, meter facilities, and other work by the Company. Examples of temporary service are those supplied to non-permanent structures, during the construction of permanent structures or projects, or for short-term service to carnivals, exhibits, decorative lighting, etc. Customer installations considered unsafe by the Company will not be energized.

3.3.2 Location

The temporary structure shall, whenever possible, be located adjacent to the permanent building so that the service may be transferred to the point of permanent attachment when the construction is completed. Typical overhead and underground temporary services are shown in [Section 4.0](#).

3.3.3 Equipment

Service entrance, meter and other wiring on temporary installations are to be installed in the same manner as required for permanent installation with respect to service-drop clearances, metering, grounding, and safety. Service entrance equipment shall be installed on a structure (see [Section 4.0](#) and [Section 5.0](#)). Inspections and approval by an authorized inspection organization shall be required prior to the Company making the service connection. The Customer shall be required to provide a substantial and adequate support, guyed if necessary.

3.3.4 Duration

Temporary service shall be permitted for holiday decorative lighting, carnivals, and for similar purposes for the ninety (90) day period permitted by the NEC. Temporary service for residential home construction shall be permitted for a period not to exceed one (1) year or two (2) years for commercial construction depending upon the applicable Company tariff.

When temporary service is a result of an emergency, the permanent service shall be re-certified according to these specifications and the NEC by the authority having jurisdiction (AHJ), or an inspection agency approved by the AHJ and accepted by the Company, within ten (10) business days.

3.3.5 Cost

In accordance with the Company's applicable tariff, the Customer may be required to pay in advance the estimated cost of installing and removing the temporary service. Estimates of the cost for temporary service to commercial and industrial installations may be obtained from the Company. If any such installation presents unusual difficulties as to metering the service supplied, the Company may estimate consumption for purposes of applying the rates as set forth in the applicable Company tariff.

3.4 Access

In accepting service, the Customer grants to identified Company employees and agents the right of personnel, vehicle, and equipment access to the Customer's premises at all reasonable times for such purposes as the reading of meters, inspection of meters, and installing, operating, maintaining, disconnecting and removing, any or all of the property belonging to the Company. Such access shall be suitable for its intended purpose. An overhead attachment shall be capable of being reached from ground at level grade with a 24-foot extension ladder.

The Company may discontinue service after reasonable notice, if access to its meters or other equipment is unreasonably refused, obstructed, or hazardous. The Customer may also be assessed a charge if access is prevented or hindered.

3.5 Identification of Employees

Employees of the Company, or its agents, authorized to visit the premises of its Customers, are furnished with photographic Company identification, which they will show upon request.

3.6 Character of Service

The Customer shall inquire of the Company as to the type of service to be supplied prior to the purchase of electrical equipment or before proceeding with its wiring installation. In response to such inquiry, the Company will designate the type of service and delivery voltage based on the location of the Customer and the size and character of its proposed load. Special consideration will be given to the selection of the type of service to supply electric motors, furnaces, welders, x-ray apparatus, EV fast chargers and other loads, which may interfere with satisfactory service to other Customers. Normally only one service is provided to a building or a structure on a premise. For multiple services to a building see Section 3.2.

In instances where the aggregate premise load exceeds the largest standard Company service transformer and loads can be provisioned in a sensible manner (i.e. large mechanical, tenant, commercial), differing voltage levels may be allowed upon Company engineering review. These instances shall be reviewed as multiple service requests (Section 3.2).

3.7 Voltages Available

3.7.1 Available Services

All new services will be 60 Hz, single-phase or three-phase alternating current designated by the Company. The following types of service in Table 3.7.1-1 are generally standard but not all types are available at all locations. To find which are available, please consult the Company. This must be done before any wiring is installed or equipment purchased.

Informational Note: The kVA limits listed in Table 3.7.1-1 are for a given SERVICE, not for the individual occupancy meters within the given service. For example, a three-phase service to an apartment building is allowed to have a combination of 100 A, 150 A, and 200 A 120/208V metered tenants. The electrician will balance the load among the three phases. A second 120/208V service from the same transformer to another premise is not allowed to exceed 100 A (20kVA).]

To serve residential, commercial and industrial loads, one of the voltage services 600V and less, listed in Table 3.7.1-1, will be supplied at the Company's designation.

Table 3.7.1-1: Available Services Below 600V

Phases	Wires	Company's Delivery Voltage (V)	Company's Typical Voltage Delivery Levels		Note
			Minimum Customer Load (kVA)	Maximum Customer Load (kVA)	
1	3	120/240	None	100	(A)
1	3	120/208	None	20	(B)
1	3	277/480	None	50	(C)
3	4	208Y/120	None	300	(D), (E)
3	4	208Y/120	None	1000	(E), (F)
3	4	480Y/277	None	500	(D), (E)
3	4	480Y/277	None	1000/2500	(E), (F)

Notes to Table 3.7.1-1:

- (A) Single-phase, 120/240V service above 50 kVA must be approved by the Company.
- (B) Where the present service is three-phase, 4-wire, 208Y/120V. Exception: In Network areas where standard service voltage is three-phase, 4-wire, 208Y/120V, refer to ESB No. 757 (Network Services) for limitations.
- (C) Where the present service is three-phase, 4-wire, 480Y/277V. This is only available subject to Company review. Three-phase, 4-wire, 480Y/277V is typically reserved for Commercial and Industrial and large mixed Commercial/Residential use only.
- (D) Demand of 150 kVA or more is generally preferred to be supplied by a pad mounted transformer service. Where overhead service is provided, transformers are limited to 3-100 kVA for 208Y/120V, and 3-167 kVA for 480Y/277V. Three-phase service normally will not be made available for a residence.
- (E) See Section 9.2.4 for non-network transformer vault services.
- (F) For areas served by 5kV class distribution, maximum Customer load shall be limited to 1000 kVA. For areas served by 15kV class distribution, maximum Customer load shall be limited to 1000 kVA at 208Y/120V and 2500 kVA at 480Y/277V.

For both new applicants and existing Customers, the Applicant or Customer shall submit a written request that includes its proposed in-service date, connected load, diversified demand, and load factor information. Refer to the [Process and Information](#) section at the beginning of this book. Customers having the potential to exceed 75 kVA of transformer capacity may be required to supply space for electrical equipment on private property in accordance with the Company's Terms and Conditions (see [Section 4.0](#) and [Section 5.0](#)). Where three-phase secondary service is requested and available and the minimum Customer load is less than 50 kVA, the Customer may be required to contribute to the supply facilities' installation cost according to the Company's tariff in the specific service area.

For service above 600V, the Company will solely designate the type of service based on the location of the Applicant or Customer and the size and character of the proposed load. Please consult the Company early in the planning process to determine the specified delivery voltage. (Ref ESB 751.) In Upstate NY, maximum demand can be limited by specific supply circuit conditions under the Company's tariff, PSC No. 220. An Applicant or existing Customer in Upstate NY with large quantifiable needs on a distribution system greater than the Company's specified limit will require a service of higher voltage characteristics offered in PSC No. 220 to efficiently and effectively manage the load supplied by the utility electric system meeting the public needs of more than one Customer. Evaluation according to Rules 4.4 and 44 in PSC No. 220 permits the Company to determine and specify the delivery voltage to the Applicant or Customer in Upstate NY. In addition, see [Section 3.8](#) for services no longer standard.

3.7.2 New Customers (Applicants)

The delivery voltage for service to a new Customer is determined based on engineering considerations such as system loading, location of electric supplies, reliability, circuit protection and coordination, planning, operation and maintenance. (Ref ESB 751)

3.7.3 Existing Customers

3.7.3.1 Customer Expansion

The new delivery voltage for service to an existing Customer contemplating an expansion that will result in a maximum Customer peak demand greater than the limit specified in Table 3.7.1-1, is determined based on engineering considerations such as system loading, location of electric supplies, reliability, circuit protection and coordination, planning, operation and maintenance. The Customer shall reimburse the Company as set forth in the applicable Company tariff. A Customer with premise "pre-wiring" that is installed under a municipal energy stretch code, but is not fully utilized, shall notify the Company before utilizing that "pre-wiring."

3.7.3.2 Voltage Migration at Customer's Request

Voltage migration may be permitted upon written request to the Company, provided: (1) such increase in delivery voltage shall be allowed only when in the Company's sole judgment, system or facility loading, reliability and safety will not be jeopardized; and (2) the provisions of the Company's applicable tariff shall apply to any such increase in delivery voltage requested by the Customer.

3.7.3.3 Voltage Migration at Company's Request

When, in the Company's sole judgment, and consistent with the Company's applicable tariffs, the Company determines that changes in delivery voltage are necessary to alleviate system or facility loading, reliability or safety problems, the Company will make such changes and will be responsible for the associated costs.

3.8 Services No Longer Standard

Electric services no longer standard include, but are not limited to: 25 Hz, two-phase systems, 2-wire 120V, 240V delta, 460V wye, 480V delta, 600V delta, 2400V, 4160V or 4800V services. Transformers rated at these non-standard voltages will no longer be provided by the Company. While 2400V, 4160V, or 4800V are no longer standard, they may still be available at certain locations; consult the Company.

Physical service configurations no longer standard include, but are not limited to: Mat and Fence and non-network vault. See [Section 9.2.4](#) and [Section 9.2.5](#).

Customers now receiving non-standard service shall not expand, upgrade, or alter the use of such service, except in very limited circumstances at the sole discretion of the Company.

Customers with an existing non-standard service requesting a service change shall consult with the Company to obtain a standard single or three-phase 60 Hz service at an appropriate delivery voltage.

3.9 Load Balance

The Customer, in taking electric service, shall connect its lighting and other loads so as to maintain as nearly as is reasonably possible, equal current in each of the line conductors at the point of delivery. Voltage unbalance resulting from unbalanced currents shall not exceed 2% or shall not cause objectionable effects upon or interference with the operation of the Company's facilities and service to others. The Company may require the Customer to install any necessary operating and safety equipment in accordance with the requirements and specifications of the Company, provided such installation does not conflict with applicable electrical codes, federal, state or municipal law. The Customer is responsible for bearing the cost of any changes necessary to correct an unbalanced load condition.

3.10 Increase in Service

Company facilities are normally designed to meet the Customer's initial electric demand requirements at the time service is installed. The Customer shall provide the Company reasonable advance written notice of any proposed increase in service required. This notice shall include the amount and character of the proposed increased service, including the timing, frequency, and duration of the peak load, as well as the date the increased load will be required. Load increases requiring changes to the supply facilities (other than metering equipment) for the sole use of the Customer may require a contribution to the Company in accordance with the Company's applicable tariff. See previous [Section 3.7](#). The Customer shall not make additions unless the Company has notified the Customer that it can supply the increased load.

3.11 Service Entrance Upgrade

The service entrance shall be upgraded to comply with the current Specifications for Electrical Installations when the Customer replaces, adds, or otherwise modifies the following equipment: Service entrance conductor; meter socket enclosure; point of attachment; service equipment replacement; modifications to a junction box or wireway; or taps on the line side of the main disconnect. Exceptions in limited circumstances are at the sole discretion of the Company.

3.12 Discontinuance of Service

The Company may discontinue service where the Customer's equipment or its operation is deemed to be unsafe or results in objectionable effects on the operation of the Company's facilities or its other Customers, consistent with the procedures set forth in the Company's applicable tariff. Reconnection of service will occur after the Customer has made the required corrections at its cost. See also Section 10.

3.13 Energy Management System

Energy Management Systems can be used for the monitor and control of loads connected to utilization equipment, distributed energy resources, and protection systems. EMS shall comply with NEC Article 750.

Customers that elect to utilize an EMS shall submit a one-line that complies with Section 3.1.4. In addition, a control diagram showing: communication pathways between the EMS and controlled loads, sequence of operations including load management and failure modes.

The Company may elect to perform a Witness Test to verify the EMS operates in compliance with NEC 750.30(C)(2) System Malfunction.

3.14 Electric Vehicle Charging

Charge only Electric Vehicle Service Equipment shall be certified by UL 2594 or UL 2202. EVSE that is certified to UL 9741 or UL 1741 shall be considered as DER and comply with ESB 756.

EVSE applications will be evaluated at 100% demand factor unless an accepted Energy Management System is applied, see Section 3.13 for EMS requirements.

Approval for charging does not mean approval for discharge.

PART B – ELECTRIC SERVICE REQUIREMENTS

4.0 SERVICE CONNECTIONS

4.1 General

Types of Service Connections

The Company offers the following service connections, depending on the Customer's location, character of service, and expected electrical demand:

- Overhead Secondary Voltage Service Connection (Under 600V)
- Overhead Primary Voltage Service Connection (from 2.4kV to 46kV inclusive)
- Overhead Transmission Voltage Service Connection
- Underground Secondary Voltage Service Connection (Under 600V)
- Underground Primary Voltage Service Connection (from 2.4kV to 46kV inclusive)
- Underground Transmission Voltage Service Connection

4.1.1 Rights-of-Way, Easements

See [Section 3.1.3](#) for property rights as a condition of service.

In UCD, URD, or multiple occupancy building applications, the Customer shall provide the Company with two copies of the approved development map, certified as final by a design professional or licensed land surveyor, which the plan shall have been recorded or filed with the Registry of Deeds. The map shall indicate lot lines, building setback lines, grade lines, sidewalk, roadway, sewer, water, drainage, overhead and underground utilities, and other facilities. The map shall also include the identification and, where appropriate, delineation of sensitive environmental resources including, but not limited to, wetlands, streams, archaeologically sensitive areas, and hazardous waste disposal areas, etc. In addition to this base information, this map shall clearly indicate the easement strips dedicated to the Company and the location of the lots (units) for which electric service is requested. The governmental authority having control over land use shall approve this map. In addition, when electronic maps are used, the Customer must consult the Company for submittal.

Rights-of-way and easements must be cleared of any obstructions at no charge to the Company. The applicant shall grade the right-of-way or easement to within six (6) inches of final grade before the Company commences construction. The applicant must maintain the Company's clearance and grading requirements.

4.1.2 Number, Routing and Location of Service Laterals or Service Lines

The Company will designate the number of service laterals or service lines required to provide service to a Customer. Normally, the Company runs only one service lateral or service line to a Customer. The Company will designate the location from which the service will be taken, the type of construction to be employed, the routing of the service lateral or service line, and the service point location. The Company will consider appearance, accessibility, available right-of-way, and the desires of the Customer in making this decision. Service laterals or service lines will not be run from building to building. When the Company's conductors supply a building or structure, these conductors shall not pass beneath or through the interior of another building or structure. Any Customer building or structure shall not encroach on the Company's line conductors and line equipment, except where transformer vaults are installed within the building served.

In certain circumstances, life safety systems may be served through a separate service, or they may be tapped ahead of the main service equipment (see [Section 5.1.5](#)). In all cases, life safety systems shall

be metered (see [Section 7.1.7](#)). The Customer shall consult with the AHJ regarding specific requirements for life safety systems.

4.1.3 Relocation of Services

When electric service relocation is at the request of the Customer, all costs associated with the relocation of the service drop or lateral on both private and public land shall be borne by the Customer.

When the service lateral relocation is the result of an order by a public authority, the Customer shall pay for that portion of the cost associated with the service lateral movement on private property. In some instances, the public authority may compensate the Customer for this expense.

When the pole from which a Customer-owned underground service lateral originates must be replaced it is the Customer's responsibility to move its service lateral to the new pole location at Customer's sole expense.

For a Customer-owned electric service lateral needing relocation, it is the Customer's responsibility to arrange with its contractor to move its service lateral. This responsibility includes coordination of this relocation with the Company and inspection of the newly relocated service lateral by an authorized electrical inspector.

Company-owned facilities involved with any relocation will be the responsibility of the Company. Refer to 759A and 759B for primary service lateral equipment responsibilities.

4.1.4 Voltage Drop Considerations

The Company recommends that the Customer's conductors from the service point to the main service equipment (see [Figure 2-1](#)) be sized to limit voltage drop to 1%. The Company is required to maintain adequate voltage at the service point. It is the Customer's responsibility to maintain adequate voltage beyond the service point.

The Customer or its representative is responsible to perform voltage drop calculations to meet these criteria.

4.1.5 Minimum Size Single-Phase Service Connections

A new single-phase service connection for an installation of one meter shall have a current carrying capacity rating of not less than 100 A, and for an installation of more than one meter, not less than 150 A. The Company, in its sole discretion may also allow non-residential type installations such as, but not limited to CATV equipment, signs, and service to traffic control systems to be a minimum of 30 A. These non-residential services that may use 100A meter socket enclosures are considered commercial and shall have a lever bypass, per [Table 7.2-2](#).

Additionally, The Company will install 200A rated billing meters, and it is therefore the responsibility of the Customer to ensure compatibility between the Company's billing meter and the customer-supplied meter socket enclosure. See [Figure 7.3-1](#) for typical details. The Company recommends ampere capacities greater than the National Electrical Code's required minimum, when significant future load increases are expected.

4.1.6 Service Conductor Splicing

Service conductors may not be spliced in the following locations:

- (A) Within conduits or anywhere above grade on Company pole, unless in the supply space at transformer by Company;
- (B) Within a meter socket enclosure.

Otherwise, service conductors may be spliced in accordance with the National Electric Code (NEC).

Where extensions within a secondary transformer compartment or within a Customer vault are necessary, splicing is done by either the Company or the Customer depending on the application: for

single-phase pad-mounted transformers, splicing is done by the Company; for three-phase pad-mounted transformers and vault installations, splicing is done by the Customer.

4.1.7 Routing of Metered and Unmetered Conductors Within a Building

Metered and unmetered conductors of any voltage shall not be installed in the same raceway, auxiliary gutters and/or pull boxes. Where unmetered conductors are run through the Customer's building, they shall be enclosed in a continuous run of (threaded) rigid metal conduit with no conduit bodies, or in a continuous run of (threaded) intermediate metallic conduit with no conduit bodies, or in service busway, or in concrete-encased ductline (which may be required by the AHJ for certain situations). The installation of pull boxes or other similar devices is only permitted on unmetered raceways on the Customer's premises with the Company's written approval.

Where unmetered plug-in type armor-clad busway is used to serve Customers in the same building, all plug-in access openings shall be provided with a steel hasp assembly for the Company's padlocking of the hinged hood in the closed position.

The sealing of unmetered raceways with lead-wire or meter seals is not permitted **except by a Company seal.**

Refer to [Section 7.1.6](#) for installation of unmetered conductors in raceways where access is required.

Unmetered conductors shall not be utilized to supply a step up or step-down transformer within the Customer's Premise wiring.

4.1.8 Temporary Service

Temporary service may include the installation of a line extension, service lateral or service line, setting meters or other extra work by the Company. The Customer may be required to pay, in advance, the entire cost of the temporary service including removal of the temporary service; see [Section 3.3](#). Temporary service is generally provided as an overhead secondary service voltage connection. The Customer will provide, as the point of attachment, either:

- (A) A properly guyed wood pole on which the service bracket can be attached. The wood pole shall be ANSI Class 7 minimum, pressure treated and of sufficient height to provide proper ground clearance for conductors. This installed pole shall be safe for climbing. Where a 25 ft pole is permitted, a 5 ft minimum burial depth is required. Installations determined to be unsafe by the Company shall not be energized. The span for the service drop shall not exceed 150 ft. Temporary service drops shall not be attached to construction trailers. This arrangement is shown in [Figure 4.1.8-1](#).
- (B) For an alternate temporary overhead service arrangement, a 6" X 6" foundation grade treated post with cross bracing as shown in [Figure 4.1.8-2](#) may be permitted.
- (C) Where conditions permit, an underground temporary service may also be obtained as shown in [Figure 4.1.8-3](#).
- (D) A building on which the service bracket can be attached to a structural member of the building or to a riser mast. The attachment shall meet the requirements for permanent attachment described in [Section 4.2.2](#).

4.1.9 Service to Manufactured and Mobile Homes, Mobile Home Parks, and Recreational Vehicle Parks

The provision of electric service to these types of structures present challenges to the Company and the Customer because general service drops and underground service laterals cannot be placed directly on the structure itself, but rather, must be metered and served through a remote meter assembly (meter pedestal or Customer service pole) and service equipment.

4.1.9.1 Service to Manufactured and Mobile Homes and Mobile Home Parks

Mobile home parks of certain sizes (number of lots) and within various locations may require the Company to comply with Underground Residential Development (URD) rules. These rules may differ by state. The Customer or Developer is urged to contact the Company prior to planning electric service to a new or expanding mobile home park to discuss the specific arrangements necessary to provide electric service consistent with the Company's applicable tariff.

When the Company determines that overhead service shall serve a single manufactured or mobile home, the Customer shall install a Customer service pole, as shown in [Figure 4.1.8-1](#). When the Company determines that underground service shall serve a single manufactured or mobile home, the Customer shall install a service post shown in [Figure 4.1.8-3](#) or meter pedestal as shown in [Figure 7.3-7](#).

Depending on the arrangement and number of manufactured or mobile homes to be served, a meter board may be installed as shown in [Figure 4.1.9.1-1](#) and in [Figure 7.3-9](#). This arrangement allows a number of metered manufactured/mobile homes to be served from the same service point, and to be metered in the same location. The Customer/Developer is cautioned to comply with the necessary load calculations as described within the National Electrical Code and to comply with the requirements as set forth by the local AHJ.

4.1.9.2 Service to Recreational Parks

Service to Recreational Parks, as defined in Section 2.0, shall be provided through one single service point. As recreational parks are privately owned, it is the Customer's responsibility to distribute its own electric service throughout the park. Due to the seasonal nature and short duration of electric service to recreational parks, it is beneficial for the Customer to maintain control of the electric distribution system on their property.

4.1.9.3 Service to Tiny Homes

Tiny homes come in various forms. If a tiny home is not affixed to a permanent foundation, it will be classified as a mobile home or recreational vehicle. The electric service requirements shall follow the appropriate section for the classification. If the Tiny Home is affixed to a permanent foundation in a modular or site-built fashion, the electric service requirements shall follow the appropriate section for that classification.

4.2 Overhead Secondary Voltage Service Connection (Under 600V)

4.2.1 General

An example of a typical Company-provided secondary voltage overhead service is shown in [Figure 4.2.1-1](#). The Company will construct, own and maintain all overhead service lines, that is, that portion of the supply circuit between the Company's secondary distribution line serving other Customers and the service point in accordance with the Company's applicable tariff. Refer to [Section 2.0](#) for the definition of the term service line.

An overhead service drop may be provided to supply services rated 800 A or less. No more than two (2) sets of service entrance conductors, with their end terminations grouped at one location shall be connected to a service drop.

At single-phase installations where the anticipated demand as determined by the Company does not exceed 72 kVA, a self-contained meter shall be used; see [Section 7.0](#). Where the anticipated single-phase demand exceeds 72 kVA, a current transformer installation shall be provided by the Company as indicated in [Section 7.0](#). Where the anticipated demand exceeds 100 kVA, three-phase service is required.

4.2.2 Service Attachment, Location

The Customer shall furnish, own, install, and maintain a 600V insulated service bracket assembly to which the Company's service drop will be attached; see [Appendix 1](#). This assembly shall be properly

affixed to a structural member of the supporting building, service pole, or riser mast, and capable of withstanding the tensions described in [Section 4.2.4.4](#) and [Table 4.2.4.1-1](#) for the size of the service being installed. Attachments to chimneys are not permitted. The service bracket shall be positioned below the service entrance conductor weatherhead as shown in [Figure 4.2.2-1](#). Company service drop attachment shall comply with NEC clearances of 12 inches to other attachments.

4.2.3 Customer-Owned Service Pole

On farms, or other locations, where several buildings or structures are under one ownership; and, where a single electric service point and billing meter are feasible (service rating, 800 A, maximum), a Customer furnished, installed, owned and maintained service pole, complete with billing meter and service equipment, may be permitted. A service pole shall be installed according to the requirements noted in the [Figure 4.1.8-1](#). All materials and methods used shall not be less than those specified in the applicable figures. For a service drop greater than 30 ft, guying of the pole is required. The Company shall be consulted in each case to determine installation requirements.

4.2.4 Overhead Service Line Clearances

National Grid's overhead service line conductors must comply with the clearance requirements of the National Electrical Safety Code and National Grid's Overhead Construction Standards. The Customer's service bracket, located near the point of attachment, must be installed in such a location to allow for minimum clearance of overhead service line conductors to be met. In all cases, the Company shall determine the location of the point of attachment. See [Section 4.2.4.2](#) for special clearances to swimming pools.

4.2.4.1 General Overhead Service Line Clearances

The general clearances in Table 4.2.4.1-1 are in effect for National Grid's overhead service line conductors. The attachment point shall be installed such that the clearances in Table 4.2.4.1-1 are maintained.

Table 4.2.4.1-1: Overhead Service Line Clearance Requirements

Clearance Requirement	Effectively Grounded Neutral, Grounded Guys and Ungrounded Guys Exposed to 0 to 300V	0 to 750V Multiplex Supply Cables
	(ft)	(ft)
Vertical clearance above roads, streets, alleys, parking lots, driveways and other areas subject to truck traffic.	17.0	17.5
Spaces and ways subject to pedestrians or restricted traffic only.	11.0	13.5
Vertical or diagonal clearances over or under roofs or projections not readily accessible to pedestrians. See Note (F) for further detail.	4.5	5.0
Horizontal clearance from porches, decks, fire escapes, or other similarly attached structures.	4.5	5.0
Vertical or diagonal clearances over or under roofs, balconies, decks, or similar structures readily accessible to pedestrians.	12.0	12.5
Maximum vertical height above ground to service drop drip loop from finished grade.	25.0	25.0

Clearance Requirement	Effectively Grounded Neutral, Grounded Guys and Ungrounded Guys Exposed to 0 to 300V	0 to 750V Multiplex Supply Cables
	(ft)	(ft)
Any direction from eavestrough or downspout.	0.5	0.5
Clearance below or horizontally around unguarded windows and doors.	3.0	3.0
Vertical above window top.	1.0	1.0
Around <u>non-opening</u> windows (with no sag adders).	1.0	1.0

Notes to Table 4.2.4.1-1:

- (A) Vertical clearance values for conductors are for 100 ft spans at 60°F (15°C) final unloaded sag and phase-to-ground voltages. No allowance is made for sag for vertical clearances at a building or structure's point of attachment. Consult the Company for clearances required for longer spans.
- (B) Vertical clearance above roadways subject to truck traffic may have higher requirements based on the highway authority having jurisdiction.
- (C) A roof, balcony, or area is considered readily accessible to pedestrians if it can be casually accessed through a doorway, ramp, window, stairway, or permanently mounted ladder by a person on foot who neither exerts extraordinary physical effort nor employs tools or devices to gain entry. A permanently mounted ladder is not considered a means of access if its bottom rung is 8 ft or more from the ground or other permanently installed accessible surface.
- (D) Where the height of a residential building does not permit its service drop(s) to meet these values or where clearances are compromised, please consult the Company.
- (E) Consult the Company if work may be expected in the future near lines or between the building and lines. The clearance shall be increased to ensure 10 ft minimum clear space for electrically unqualified persons, tools, machinery, and equipment or the line must be de-energized, guarded, and marked-up as required by safety codes. The clearance shall consider space required when ladders, lifts, or scaffolding are to be used when maintaining the building or structure. The Customer will be responsible for any charges incurred by the Company to provide safe clearances for Customer activity.
- (F) This clearance is measured from the lowest point of the conductor (including the drip loop). The clearance may be reduced to 18 in within 6.0 ft of the riser mast or attachment support if the riser mast or attachment support is not more than 4.0 ft from the edge of the roof. Beyond 6.0 ft, **and over the same continuous roof**, the clearance may be reduced to 3.5 ft.
- (G) For clearances of any wires, conductors, cables, and unguarded live parts adjacent but not attached to buildings, consult the Company.

4.2.4.2 Clearances to Swimming Pools

National Grid follows the latest revision of National Electric Safety Code (NESC) with respect to allowable clearances, including clearances between electrical equipment and swimming pools. Customers or their authorized agents proposing to install a swimming pool within 30 ft, horizontally, of overhead wires shall contact National Grid to arrange for a site visit by a Company representative. This shall occur prior to the construction or installation of the pool. The Company will reply in writing with any clearance restrictions found.

Swimming pools are not to be located less than 5 ft horizontally from underground cables. Underground utility locations must be requested prior to swimming pool construction as described in the [Safety Information](#) Section. The Customer or their authorized agent shall contact the Company if any buried electrical utility cables are identified.

Clearance violations caused by the placement of an above ground or in-ground swimming pool must be corrected to remove the potential hazard. The Customer will be responsible for the relocation of the swimming pool or the cost of relocation of the Company's electrical facilities (poles, wires, transformers, etc.) to meet the Company's minimum clearance specifications. Electric service will be discontinued if the clearance violation cannot be made safe within a reasonable time frame as determined by the Company. See [Section 3.11](#).

[Appendix 3](#) contains the text, illustrations, and tables derived from NESC Rule 234E1 that the Company follows in determining swimming pool clearances to overhead wires. **Under no circumstances should anyone, other than qualified Company personnel, attempt to measure clearances to the Company's electrical facilities.**

4.2.4.3 Service to Low Buildings

Where the Customer's building or structure is too low to serve as the attachment point for the service bracket, and clearances described by [Section 4.2.4.1](#) cannot be met, the Company shall be consulted. When National Electrical Code and National Electrical Safety Code standards permit, the Customer can submit the matter to the Company which may approve the installation of the service bracket at an alternate point. As another alternative, the Customer may install a service "riser" to mount the service bracket at the required height. See [Section 4.2.4.4](#).

4.2.4.4 Riser Mast Requirements

Service risers shall be galvanized rigid steel conduit or a galvanized structural steel member similar to the design shown in [Figure 4.2.4.4-1](#). This service riser shall be capable of withstanding the service drop tensions in Table 4.2.4.4-1. The conduit for service riser masts shall be at least 2-1/2 inches. Where mast heights exceed the maximum heights allowed by Table 4.2.4.4-1, an anchor shall be installed to resist the bending moment imposed by the wire as shown in the bottom of the table. Where clearance remains a problem, the Company recommends the Customer install an underground service lateral and service conductors as described in [Section 4.5](#).

Table 4.2.4.4-1: Galvanized Riser Mast Bracing Requirements

Galvanized Steel Riser Mast				
Maximum Unbraced Height from Roof to Attachment Bracket				
See Details in Figure 4.2.4.4-1	Service Rating			
	1-Phase 200 A & Below	3-Phase 150 A	1 or 3-Phase 400 A	3-Phase 800 A
	Lb	Lb	Lb	Lb
Service Cable Tension →	650	680	1000	2000
Riser Material:	In	In	In	In
Angle Size				
3" x 3" x 1/4"	30	30	N/A	N/A
3" x 3" x 3/8"	42	42	24	2 @ 24 ea.
3-1/2" x 3-1/2" x 3/8"	48	48	42	2 @ 42 ea.
Channel Size				
6" x 2" - 8.2 lb	24	24	N/A	N/A
8" x 2-1/4" - 11.5 lb	42	36	24	2 @ 24 ea.
9" x 2-1/2" - 13.4 lb	48	48	30	2 @ 30 ea.
I-Beam Size (Detail B)				
4" x 2-5/8" - 7.7 lb	36	30	N/A	N/A
5" x 3" - 10.0 lb	48	48	36	2 @ 36 ea.
6" x 3-3/8" - 12.5 lb	48	48	42	2 @ 42 ea.
Nom. Diameter Steel Conduit (Detail A)				
2.5"	36	30	24	2 @ 24 ea.
3"	48	48	36	2 @ 36 ea.
3.5"	48	48	48	2 @ 48 ea.
4"	48	48	48	2 @ 48 ea.
Minimum Guy Wire Bracing	5/16"	5/16"	3/8"	1/2"

Note to Table 4.2.2.4-1: For single-phase, 200A and less service drops, a 2-inch (53) rigid galvanized steel conduit riser may be permitted providing it is braced with a 5/16" (8mm) steel guy wire. See Section 1.11.1 when considering alternative installation methods and materials.

4.2.5 Service Drop and Connection to Service Conductors

The Customer shall furnish, install, own and maintain all service entrance conductors. The Company shall make all connections, permanent or temporary, between the overhead service drop and these entrance conductors. The Company will not permit this connection to be made by others, unless as specifically described in [Section 4.2.6](#) below.

Upon initial installation, a minimum of 36 inches of service entrance conductor shall be extended beyond the weatherhead for service connection by the Company. Manufactured weatherheads shall be mounted vertically and filled with duct seal to inhibit water penetration. Goosenecks are not permitted.

The service entrance conductor itself, or the conduit, or wireway containing the service entrance conductors, shall be exposed from the connection at the service drop conductors to the meter location, except where this service entrance directly passes through a roof or building wall. These openings shall be weatherproofed to prevent the entrance of water and protect the service conductors from physical damage up to the service equipment. Installation of service entrance conductor or conduit shall be mounted on the external face of the building wall (not within the wall cavity and not within the interior of the building).

4.2.6 Residential Overhead Service Upgrade

In Upstate NY, where there are no jurisdictional requirements for licensed electricians, the Company will permit individuals with qualifications as outlined in the National Electrical Code (NEC) to disconnect and temporarily reconnect a residential overhead service.

To do this, the following conditions must be met:

- (A) Residential single-phase overhead service of 200 A or less.
- (B) The point of attachment is accessible from the ground by a ladder.
- (C) There is no change in the point of service location.
- (D) Temporary mechanical/bolted connections can be made on the Customer's side of the service point after the upgrade has been completed.
- (E) Service drop maintains minimum clearances according to Section 4.2.4 and the NEC.

The licensed electrician or individual with qualifications as outlined by the NEC must make arrangements first by contacting the Company in accordance with the Company's applicable tariff. See the [Process and Information](#) section on obtaining electric service and the inside front cover of this book.

4.3 Overhead Primary Voltage Service Connection (2.4kV to 46kV inclusive)

Refer to the Company's Electric System Bulletin's 751, 752, 753, and 755 for installations within National Grid's New York Service Territory Only.

Primary service, by its nature, provides more opportunity for a given primary Customer to directly affect other electric system Customers. Primary Customers are responsible for obtaining and maintaining their own equipment. (Refer to the Company Electric Service bulletin 755.)

The Company provides a number of services of this type. Normally, such services are three-phase. Depending upon site location, actual service voltage, and use characteristics, certain load restrictions may apply. Customers within National Grid's New York Service Territory who require primary voltage service shall refer to ESB 751, 752, 753, and 755, as applicable, which is reviewed and approved by the Company prior to energization. The Customer shall contact the Company prior to planning for an overhead primary voltage service.

The Company constructs, owns and maintains all overhead primary service lines in the voltage range from 2,400V and above. Where intermediate support is required, or an extension of the primary service lateral or line is necessary, the Customer may be required to contribute to the cost of that portion of the service lateral or service line, in accordance with the Company's filed tariffs.

When the service lateral terminates in a building or vault, the section between the last pole and the building or vault shall be an underground cable.

4.4 Overhead Transmission Voltage Service Connection

Refer to the Company's Electric System Bulletins 751 and 752.

Customers within National Grid's New York Service Territory may accept transmission level voltage service (69kV and above) and shall consult with the Company so that all details concerning the design and installation of the service lateral or service line may be worked out to the mutual satisfaction of both the Customer and the Company. Refer to the Company's ESB 752 for details regarding this service type.

4.5 Underground Secondary Service Voltage Connection (Under 600V)

4.5.1 General

The Company will make the final connection to the Customer's underground service conductors in accordance with [Section 3.7.1](#) – Available Services by one of the following methods:

- (A) See [Figure 4.5.1-2](#) for residential meter socket enclosure connections for direct buried and cable-in-conduit service conductors.
- (B) Underground secondary service connection from the Company's overhead distribution supply line (see [Figure 4.5.4.2-1](#))
- (C) Underground secondary service connection from the Company's underground supply line, including network service.

At single-phase installations where the anticipated demand as determined by the Company does not exceed 72 kVA, a self-contained meter shall be used; see [Section 7.0](#). Where the anticipated single-phase demand exceeds 72 kVA, a current transformer installation shall be provided by the Company as indicated in [Section 7.0](#). Where the anticipated demand exceeds 100 kVA, three-phase service is required.

4.5.2 Facilities in Shared Trench

The use of a common trench for Customer owned underground facilities and Company distribution lines is not permitted; however, a perpendicular crossing may be allowed after approval by the Company. The Company shall be consulted when its underground distribution line or service lateral cable is involved with a trench shared with other underground facilities. The Customer underground service lateral may be installed in same trench with other buried facilities in accordance with NEC, NESC and the mutual agreement of all trench occupants.

4.5.3 Conduit System

Certain conduit construction techniques are essential to maintain the integrity of an electric service over its lifetime. For services less than 600V, Company conduit requirements are minimal, covering only situations where both the Company and the Customer have a mutual interest; however, the Customer's conduit installation shall meet the National Electrical Code. The Company requires that all conduits on the line side of the revenue metering be installed in a secure manner. No conduit body fittings (condulets) or unlocked access panels are permitted. For network services and services above 600V, where the Company furnishes, installs, and thereafter maintains the cable, there are more requirements as noted in this book and National Grid's ESB 757, 759A and 759B.

Where conduit installations are made, it is especially important where future placement of conduit will be awkward, time consuming, and costly that a spare conduit be provided. Spare conduit is required for primary service laterals. Where the underground secondary voltage service cable terminates on the outside of a building in a meter socket enclosure or wireway, the cable shall be protected by conduit with expansion fitting for frost protection. Where the underground secondary voltage service cable terminates in a building, the cable up to the point of termination on the Customer owned service equipment shall be protected by conduit.

For services supplied from radial underground systems, the Customer shall seal conduits where they enter the building to limit water ingress from either around or within the service conduits. For services supplied from the secondary network, the Customer shall install a fire-stop conduit seal to limit ingress of water, smoke, fire, and hazardous gases from either around or within the service conduits. The Customer

is responsible for meeting the NEC and any other code requirements as necessary for sealing of underground conduits.

4.5.4 Underground Secondary Service Connection from the Company's Overhead Distribution Supply Line

4.5.4.1 Customer-Owned Underground Secondary Service Conductors

Where the Company elects to provide service from its overhead distribution supply line, the Customer shall own, operate, and maintain the underground service conductors from the service point at the Company's supply line to the service equipment. The Customer's underground service conductors installed in the public way shall be as permitted by the Company's applicable tariff. The Customer shall also be responsible for the conduit, fasteners and trenching required to attach to the Company's distribution pole. The conduit for underground service risers shall be maximum of two Schedule 80 or RGS conduits per pole. Contact the Company if the arrangement requires more than two conduits per pole.

Where the Company's pole is not located on the same side of the road as the proposed underground service, the Customer shall contact the Company to discuss the necessary arrangements. In some instances, and in some roadway jurisdictions, the Customer may be allowed to install their own conduit and underground service cable across the road. Otherwise, the Company may be required to install an additional distribution pole to provide this type of service. In these instances, as is the case with all Customer riser pole installations, the Company requires an inspection of the installation, including the riser pole location, fastening and grounding only after the Company has set the required pole and all work in association with the electric service has been completed. Note, depending on the roadway jurisdiction and if service is in the public way, a petition to the roadway jurisdiction may be required.

If the Company is required to change the location of the pole on which a Customer owned underground service terminates, the necessary changes to the Customer owned underground service shall be at the Customer's expense.

4.5.4.2 Company Riser Pole Attachments

The Company will permit the use of PVC Schedule 80 conduit on secondary voltage service riser poles. The conduit shall be placed, in a location on the pole away from traffic with an unobstructed path straight up the pole. See Figure 4.5.4.2-1 for requirements.

4.5.5 Underground Secondary Service Connection from the Company's Underground Supply Lines

4.5.5.1 General

Services of this type are normally found in urban areas, network areas and underground residential developments (URD). Special considerations apply to each category. For the most part, except for URD, all require cable-in-conduit construction, with the conduit encased in concrete (3-inch envelope). Network services, because of the high fault currents available in such systems, require more attention. Reference ESB 757 for Network Service installation guidance. All direct connections to Company-owned cable shall be made by the Company. The Customer shall provide the Company with a compression type splice, listed for the application. All cable sections shall be taped by the Company and secured to the satisfaction of the Company. The Company will not make direct connections to the Customer's main switch or fuse box.

4.5.5.2 Radial Fed Underground Secondary Services

4.5.5.2.1 General

For urban areas, where radial underground secondary service is provided, services shall be limited to 200 A 208Y/120V three-phase and 200 A 120/240V single-phase. Any service larger than these limits must provide a location for Company equipment, as stated in [Section 3.7.1](#).

Service termination shall be allowed to occur in a hand-hole at the two-foot line, or if the green space is not available, in a termination box located inside the Customer building. The Company shall not be responsible for any civil work on private property.

If additional service conduit and cable are required on private property to complete the service installation, they shall be in accordance with [Section 4.5.3](#).

4.5.5.2.2 Termination at Two-Foot Line

The Customer will install the underground service on private property from a hand-hole (HH) or manhole (MH) at the two-foot line as follows:

Before proceeding with the work, the Customer shall consult with the Company as to the location of the service conduit at the property line. The Customer shall then install a HH or MH two feet inside the property line, at the location of the Company's service conduit, to provide means for connection to the Company's cable. The HH or MH shall be constructed in accordance with the Company's specifications, as found in ESB 759A. Service conduit and cable required beyond this point to the Customer's building shall be installed by the Customer. At least eight (8) feet of cable shall be left in the HH or MH by the Customer for proper jointing purposes.

4.5.5.2.3 Termination at Termination Box Inside Customer Building

If a HH or MH cannot be installed at the two-foot line, the Company will install the service conductors in a Customer-installed conduit, at the Customer's expense up to a termination box, located inside the Customer's building, as follows:

Before proceeding with the work, the Customer shall consult with the Company as to the location of the service conduit at the property line. The Customer shall then install all conduits and the termination box on private property, subsequently to be used by the Company for installation of service conductors, in accordance with the Company's Specification, as found in ESB 757, Section 2.3 for 100A or 200A 120/240V services (except requirements 1h, 1j, 4b, 4c, and 5a), and Section 2.4 for 200A 120/208V Services (except requirements 1h, 1j, 4b, 4c, and 5a). All plans shall be submitted to the Company for approval, prior to construction.

4.5.5.3 Network Areas and Underground Lines

In certain urban areas within the Company's service territory, Customers will be served by the Company's "general" network, or "spot" network. The network system has redundant facilities that are the most reliable power supply for large loads in a dense urban area. Customers will receive a "general" network service, at 120/208V, single-phase or 208Y/120V three-phase. Customers having larger loads, will receive service through the Company's "spot" network at either 208Y/120V or 480Y/277V.

Due to the various locations where the Company provides network services and the differences in operational and design requirements for the various networks, Customers must contact and coordinate the requirements of network services with the Company. Reference ESB 757 for Network Service installation guidance.

4.5.6 Underground Residential Distribution (URD) Areas

Service within an Underground Residential Distribution Area shall be taken from the Company's transformer, or, the Company's handhole.

The Customer shall furnish, install, own and maintain the underground secondary service conductors between the Company's underground system supply point (in this instance, the supply point and service point are the same) and the Customer's service equipment. The Customer shall install approved underground secondary service conductors and shall tightly seal conductor ends to prevent entrance of moisture (See [Figure 4.5.6-1](#)). The Company may refuse to energize the service if conductor ends are not moisture sealed. The Customer shall dig to approximately 1 ft from the Company's transformer base or service handhole, and leave a coil of cable of at least 6 ft. After inspection agency approval, the underground service conductors shall be backfilled prior to the Company energizing the service.

4.5.7 Underground Secondary Service Connection

4.5.7.1 Underground Secondary Service to Meter Pedestals and Meter Posts

Meter pedestals are free-standing units intended to be mounted outdoors on a concrete pad in conjunction with underground wiring. If a free-standing meter pedestal is used, it shall extend a minimum below the finished grade or ground line with stabilizing means extending below the frost line to ensure that the meter mounting stays in a plumb position. See [Section 7.0](#) for further details. Meter pedestals for self-contained metering must be listed devices and shall also incorporate service equipment, but these are not intended to replace the service disconnecting means required at the building.

Meter posts are free-standing units intended to be mounted outdoors in conjunction with underground wiring. The meter post shall be extended below the finished grade and self-stabilized, extending below the frost line to ensure that the meter mounting stays in a plumb position. See [Figure 4.1.8-3](#) for further details. Service equipment shall be mounted on the meter post or meter pedestal. Additional disconnecting and overcurrent devices may be required at the building as necessary.

4.5.7.2 From a Company-Owned Primary Underground Service Lateral

Depending on the nature of service and/or the distance to the nearest Company supply point, the Company may be required to extend primary service lateral conductors and a Company-owned transformer, on private property. As outlined below and in the Company's ESB 759A or ESB 759B, the Customer is responsible for installing a suitable trench, with conduit when necessary, and provisions for a pad-mount transformer. Individual service connection requirements are provided within ESB 759A or ESB 759B.

4.5.7.3 From an Outdoor Single-Phase Pad Mounted Transformer

Refer to [Section 9.0](#) and ESB 759A for the single-phase pad mounted transformer provisions.

4.5.7.4 From an Outdoor Three-Phase Pad Mounted Transformer

Refer to [Section 9.0](#) and ESB 759B for the three-phase pad mounted transformer provisions.

4.5.7.5 Service to Buildings Requiring Multiple Meter Rooms or Multiple Meter Locations

These services, in large multiple occupancy buildings such as in [Figure 4.5.7.5-1](#), present many unique challenges and often require extensive off-site and on-site electrical system work by the Company. The initial goal for services of this type is the submittal of an approved plot plan complete with electrical facilities shown. Be sure to refer to the requirements in [Section 3.1](#), [Section 3.4](#), [Section 4.1.1](#), and [Section 4.1.7](#) in particular. The appropriate Company representative will outline the service connection requirements necessary to provide electric service to the building and its tenants. The following criteria apply to the service conductors and unmetered risers.

- (A) The Company's preference is to group the service entrance equipment and all meters in a single location where the service entrance conductors enter the building.
- (B) Feeder bus duct risers, as an alternate to cable, may be installed between the service equipment and the meter centers.
- (C) Tap boxes or provisions for plug-in units between meter centers are not permitted.
- (D) It is recommended that the proposed unmetered risers meet the minimum voltage drop provisions in accordance with the National Electrical Code, Article 215.
- (E) If the proposed unmetered risers are considered inadequate by the Company, then a single meter room will be required adjacent to the service point.
- (F) Meter rooms in multi-floor buildings shall be vertically aligned.

The nature of these facilities suggests that the meters be located within the building, all individual meter rooms need to be constructed such that the Company has access to the meters at all reasonable times.

See [Section 5.4](#) for more specific details on the service equipment and disconnects required.

4.6 Underground Primary Voltage Service Connection (from 2.4kV to 46kV inclusive)

Refer to the Company's Electric System Bulletins 751, 752, 758, and 759B, and consult with the Company so that all details concerning the design and installation of the primary service lateral may be worked out to the mutual satisfaction of both the Customer and the Company. Also, see [Section 7.0](#) for metering requirements.

Primary voltage services must be installed within galvanized rigid steel conduit, see ESB 759B.

4.7 Underground Transmission Voltage Service Connection

Refer to the Company's Electric System Bulletins 751, 752, 758, and 759B.

The Customer shall consult with the Company in every case where the service lateral will be above 15,000V so that all details concerning the design and installation of the service lateral may be worked out to the mutual satisfaction of both the Customer and the Company. Refer to supplement ESB 752 or 758 or 759B for details regarding this service type and see [Section 7.0](#) for metering requirements.

4.8 Access Roads

Where a Customer is required to furnish and maintain an access road to be used by the Company for construction and access to the Company's facilities, the access road shall meet these minimum requirements:

- (A) Maximum grade shall be no more than 8%.
- (B) Minimum width of the road shall be 20 feet and shall consist of a stabilized stone surface.
- (C) The maximum distance between the edge of the access road and the location of the Company's equipment placements shall be no more than 10 feet with less than 5-degree grade change. Greater than 5-degree grade change will require site specific approval.
- (D) A turnaround area for vehicles to exit without backing up should be provided where possible.
- (E) The minimum width of an entrance gate (if provided) shall be at least 18 feet, or greater if the entrance radius dictates. The gate shall be capable of accommodating a Company lock, either by a "married" lock arrangement or by some other agreed arrangement.

Any deviation from this requirement shall only be made upon the Company's written approval.

4.9 Labeling Specification

All Utility required marking shall be preprinted or engraved (no hand marking), have a minimum 5-year warranty for indoor or sheltered applications and have a minimum of 25-year warranty for use in outdoor applications. Labels shall be replaced when they no longer meet the legibility requirements of ANSI Z535.4. Labels shall be UL 969 compliant. Materials used shall be weather resistant, UV stabilized and suitable for the environment where it is installed. Labels may be of engraved plastic, metallic foil, or polymer plastic mechanically or adhesive applied. Pole mounted labels shall be nailed. For labels using adhesive, ultra-high strength bond adhesive shall be required.

5.0 SERVICE EQUIPMENT

5.1 General

Most of the Company's requirements in this section account for specific Company operating practices or concerns. Company imposed requirements address in particular: network services, where high fault values are available; theft of service precautions; and certain required service configurations to permit the Company to operate its supply system in a safe and reliable manner for all Customers. **Customer service equipment rating does not dictate nor guarantee supply capacity from the Company.**

5.1.1 Service Equipment Required

Service Equipment shall be furnished, installed owned and maintained by the Customer as part of the permanent wiring of each service entrance for any Company-provided service.

All service equipment shall meet the requirements of the National Electrical Code and any applicable local codes or ordinances. Service equipment rated above 400 A shall also meet the requirements of the American National Standards Institute and National Electrical Manufacturers Association (NEMA) as well as the additional requirements as outlined in this section. All service equipment housed in a compartment shall be adequately ventilated to limit the temperature rise in accordance with the latest NEMA Standards.

As stated in the National Electrical Code (NEC), Customer service equipment shall be located at the nearest point of entrance of the service conductors and ample workspace shall be provided. On group installations, all service equipment shall be grouped at one location and permanently marked by the Customer to clearly identify the space, office, store, apartment, etc. to which it is connected.

Where required by the NEC or AHJ, accessible outdoor emergency disconnects for one- and two- family dwellings shall maintain a hot sequence arrangement.

5.1.2 Service Equipment Minimum Continuous Current Rating

For single residential and small commercial applications, service equipment shall have a minimum rating of 100 A. Consult the Company for acceptable minimum service equipment ratings for other uses.

5.1.3 Service Equipment Minimum Short Circuit Withstand Capability

Service equipment shall be suitable for the short circuit current available at its supply terminals. For residential single-phase services supplied from the Company's radial supply system, the minimum short circuit withstand current shall be no less than 10,000 A RMS symmetrical. For services supplied directly from a transformer, see [Section 9.3](#) for available fault current. For network services, see [Section 5.3](#).

5.1.4 Routing of Metered and Unmetered Conductors

See [Section 4.1.7](#). Portions of the service equipment shall have provisions for security locking by the Company from the supply point to the metering location where they contain unmetered conductors.

5.1.5 Taps Ahead of Main Service Equipment

Any tap made ahead of the main service equipment for life safety systems, control power for circuit breaker, etc. shall be provided with disconnecting means and overcurrent protection adequate for the duty. Such connections shall be made only where specifically accepted by the Company and approved by the NEC.

Taps and/or splices within wireways/auxiliary gutters, ahead of main service equipment, shall be made as per the NEC. Bite connectors are prohibited. Refer to [Figure 7.4.1-2](#).

5.1.6 When Service Equipment Ahead of Metering is Required (Cold Sequence)

Refer to Section 7 for accepted metering configurations where a Customer shall install main service equipment ahead of metering in applications 600V and less. Consult the Company for metering and service equipment configurations in applications above 600V. Any service equipment located on the line side of meters (cold sequence) shall be an enclosed type. Disconnecting devices such as pull-out fuse cartridges and similar, which result in exposed live parts, are prohibited for use as cold-sequenced service equipment.

5.1.7 Service Equipment on Service Poles, Pedestals, or Posts

Service equipment must be installed by the Customer on all service poles, pedestals, or posts.

Note: Conduit is required for all service entrance conductors installed underground between the meter and service equipment.

5.1.8 Service Equipment Arrangement

The Service Equipment shall consist of one or more circuit breakers or fused disconnects in accordance with the NEC.

- (A) Circuit breakers and fused disconnects must be grouped in one location.
- (B) A main service disconnect is required where the number of line connected meters exceeds six (6).
- (C) Reference [Table 7.2-1](#) for appropriate meter sequencing.
- (D) See National Grid's Electric System Bulletin 757 for requirements pertaining to secondary network services and services less than 600V from an underground distribution line (excluding URD and UCD).
- (E) A Customer-designated emergency life safety system that requires separate service equipment shall comply with the NEC.

Where multiple service equipment is provided for either commercial or dwelling occupancy, each disconnecting means shall be labeled in accordance with specifications outlined in [Section 4.9](#).

5.1.9 Service Equipment Minimum Attributes

Service equipment 600V and less shall meet the following minimum requirements:

5.1.9.1 Interrupting Rating

See [Section 5.1.3](#) and the National Electrical Code to select proper service equipment to withstand the maximum available fault current from the Company's supply and utilization equipment contribution.

Overcurrent protection shall provide fault interrupting capability, at service voltage, not less than the value specified by the Company (see [Section 9.0](#)).

The disconnecting means shall be capable of opening load current.

5.1.9.2 Inductive Heating

Current carrying parts shall be sufficiently spaced from enclosure metals to prevent inductive heating. Enclosures of nonferrous metals may be used, if desired and listed for the application.

5.1.9.3 Metering Transformer Space

Where used, provide required space and accessible mounting facilities for the Company's metering transformers. See [Section 7.4.1](#) and [Section 7.4.6](#) for details.

5.1.9.4 Bonding

All non-current carrying metal parts, mounting brackets, frameworks, enclosures, etc. shall be bonded to an equipment ground.

5.1.9.5 Spare Fuses

Where a switch and fuse combination are used, the Customer shall be responsible for maintaining a readily accessible stock of spare fuses.

5.1.9.6 Circuit Breaker

If an air circuit breaker is used, it shall meet the following requirements in addition to those in [Section 5.1.9.1](#) and [Section 5.1.9.4](#) above.

5.1.9.6.1 Control Circuit Protection

A control circuit used only for closing the circuit breaker may be connected on its line side provided the tap is protected by high interrupting capacity fuses of a type acceptable to the Company.

5.1.10 Instrumentation and Control Wiring

All instrumentation and control wiring shall utilize stranded conductors rated for the use intended, refer to IEEE Std. 525 for a design and installation guide of cable systems.

5.2 Residential

It is recommended that service equipment for a residence include the necessary feeder and branch circuit protective devices in accordance with the National Electrical Code.

5.3 Network Service

5.3.1 General

It is important that the Company be consulted at an early stage concerning the design and coordination of the service lateral connections with the service equipment when the supply is from a network system. Refer to ESB 757 for details on receiving service from the Company's secondary networks.

5.4 Multiple Occupancy Building Service

The Company will only meter at the voltage of the service point. The Customer should be aware of any applicable state laws and tariffs regarding tenant metering arrangements.

In multiple occupancy buildings several stories high, the installation of unmetered risers in conduit to approved, accessible meter centers located on various floors shall conform to the following criteria and be reviewed by the Company for acceptance.

- (A) Disconnecting and protective equipment shall be provided at the service entrance point for each floor level(s).
- (B) Disconnects at the service point shall indicate the floor level(s) served.
- (C) Disconnecting and protective equipment shall be provided at each grouped meter location. The purpose of this requirement is to allow isolation of equipment on a specific floor without affecting the service to other floors. The disconnect on each floor shall be a load-break disconnect switch, fused disconnect switch, or circuit breaker located within close visual proximity of the proposed meter assembly and shall be capable of being locked in the open and closed positions. See Figure 4.5.7.5-1.
- (D) Any disconnect, pull box or any access to unmetered conductors shall have provisions for sealing by the Company.

5.5 Service Equipment Above 600V

The Customer shall consult the Company in every case where the service voltage may exceed 600V. The Company will designate the type of service based on the location, size and nature of the proposed load and its relation to the Company's facilities. See Company's Electric System Bulletin Nos. 751, 752, 753, or 758 for further details.

6.0 GROUNDING

6.1 General

This section applies to services 600V and below. Refer to the applicable supplements to these specifications and consult the Company for grounding applications above 600V.

6.2 Equipment to Be Grounded or Bonded

The Customer shall provide an effective ground and shall connect it to the service equipment and the following equipment in accordance with the National Electrical Code (NEC):

- (A) The grounding stud of a self-contained meter socket enclosure for existing meter pole services without service equipment. See [Section 5.1.7](#) for new service poles.
- (B) The grounding stud of a transformer rated meter socket enclosure from the Customer's service ground where not attached to the transformer.
- (C) Where the transformer rated meter socket enclosure is attached to the Company's pad mounted transformers, the grounding stud shall be connected to the transformer ground grid.
- (D) The grounding stud and neutral bus of the service equipment.
- (E) All metal service enclosures and conduits via appropriate bonds.
- (F) The frames and secondary neutral of all instrument transformers via appropriate bonds.
- (G) The rigid metal conduit riser on the Company's pole at a point ten (10) feet above ground.
- (H) CSST gas piping systems shall be bonded to the electrical service grounding electrode system at the point where the gas service enters the building in accordance with NFPA 54. The bonding jumper shall not be smaller than 6 AWG copper wire or equivalent.

6.3 Grounding and Bonding Methods

- (A) All grounding shall be done in accordance with the NEC, as a minimum, or any other applicable code enforced by the inspection authority having jurisdiction. The Company is not responsible for problems or damage to Customer equipment due to a less-than-optimum grounding electrode system. The Company shall not be liable for damage to the property of the Customer resulting from unbalanced voltage conditions due to the opening of a neutral service conductor.
- (B) In the absence of a suitable water piping system, the Customer's grounding system shall consist of electrodes as permitted by the NEC.
- (C) Achieving a lower resistance to ground value than required by the NEC provides better protection from lightning transients and can help improve power quality. A single grounding electrode, which does not have a resistance to ground of 25 ohms or less, shall be augmented by additional electrode(s) in accordance with the NEC.

6.4 Grounding Restrictions

Exclusive of the above requirements:

- (A) Gas service piping and gas meters shall not be used as a grounding electrode for the connection of a grounding electrode conductor.
- (B) A supplemental electrode bonding jumper shall not be connected to the meter socket enclosure.
- (C) The meter socket enclosure shall not be used to ground other equipment.
- (D) Consult the Company on existing three-phase delta services no longer standard where the service conductors shall be insulated from the service equipment according to the NEC and grounded only at the Company's supply transformer.

6.5 Ground Fault Protection

The Customer shall install ground fault protection for its equipment in accordance with the NEC.

7.0 METERING

7.1 General

The Company will furnish, install, own, maintain, and connect all meters required for billing purposes solely at the delivery voltage on the Customer's side of the service point in accordance with the Company's applicable tariff and applicable state laws and regulations. This includes meter instrument

transformers and meter cable when required. No service shall be left unmetered. The Company's metering equipment shall not be used to operate any Customer devices except for metering pulse signals as permitted in [Section 7.6](#). The Customer, regardless of equipment ownership, shall permit minor alterations by the Company for the metering purpose.

7.1.1 Meter Location and Access for New or Upgraded Services

It is in the interest of both the Customer and the Company that a suitable and adequately protected meter location be provided to ensure accuracy and to facilitate installation, reading, and maintenance. All metering equipment must be readily and safely accessible to the Company's personnel at reasonable times. The Company will designate this location. The Company requires the Customer to install its service wiring so that the meter is accessible to Company employees from the outside of the Customer's building in accordance with the Company's applicable tariff. Meter installations for services 600V and less, up to and including 320 continuous amperes, normally will be located outdoors.

When a service upgrade, relocation, or replacement is requested or required, the installation shall be furnished by the Customer at the Customer's expense in accordance with these specifications. Where there is an existing indoor meter(s), it shall be relocated to the outside of the building, except in very limited circumstances at the sole discretion of the Company.

Meters shall not be installed in, or allowed to remain in areas that later become, stairways, fire escapes, coal bins, fruit cellars, bathrooms, toilets, bedrooms, attics, store windows, and/or transformer vaults. Meters shall not be located behind shelves; over window wells; over equipment exhausts; near moving machinery, gas regulator vents, any flammable or hazardous material storage areas; or similar encumbered, unsuitable, or hazardous locations (see [Section 7.1.4](#)). None of the preceding hazards shall be located within the working clearance envelope defined in [Figure 7.1.2-1](#). The meter shall be located over level grade.

7.1.2 Working Clearances

Meter socket enclosure(s) should have a minimum of 3 inches of free space on all sides to accommodate access and removal of the meter socket enclosure cover(s).

7.1.2.1 Indoor Installations

In those cases where transformer rated meters or grouped meters are installed indoors, they shall be located as close as practicable to the point where the service enters the building and adjacent to the service equipment.

For multiple metering centers, the mounting height to the center of the meters shall be 6 feet maximum and 2 feet minimum above the indoor finished floor elevation.

A clear working space of at least 4 feet shall be provided and maintained in front of all meter socket enclosures with a minimum headroom of 84 inches. The working space shall be 30 inches wide. The 30 inches measurement can be made from either the left or right edge of the meter socket enclosure. In addition, meter socket enclosures with lever bypass handles must have an operating space of 30 inches to the right of the left edge of the meter socket enclosure, with a four ft depth. See [Figure 7.1.2-1](#).

7.1.2.2 Outdoor Installations

The mounting height of individual or 2-6-meter ganged meter enclosures shall be mounted with the center of the meter 5-1/2 feet maximum and 3-1/2 feet minimum above final grade. For multiple metering centers having excess of 6 meters, the mounting height of the center of the individual meters shall be 6 feet maximum and 2-1/2 feet minimum above final grade outdoors. A clear working space of at least 4 feet shall be provided and maintained in front of all meter socket enclosures, but shall not be less than 3 feet to a property line. There shall be a minimum headroom of 84 inches. The working space shall be 30 inches wide. The 30-inch measurement can be made from either the left or right edge of the meter socket enclosure. In addition, meter socket enclosures with lever bypass handles must have an operating space of 30 inches to the right of the left edge of the meter socket enclosure, with a 4 foot depth (see [Figure 7.1.2-1](#)).

For Traffic Signal services where the Company's service drop is attached to the Customer's traffic pole structure in the public way, see [Appendix 2](#) – Traffic Control Metered Service Requirements.

7.1.2.3 Electric and Gas Meter Clearances

Electric meters shall not be located above or below gas regulating vents and must maintain a minimum 36" horizontal distance from a gas regulating vent. In all cases, the Gas Service Provider shall be consulted regarding the location of gas meters near electric meters or electrical equipment (see [Figure 7.1.2.3-1](#)).

7.1.3 Physical Protection

Electric Meters shall be located away, or fully protected in a manner acceptable to the Company, from opening doors, commercial driveways, areas used for the piling of snow and where, in the Company's determination, the meter or service entrance is subject to damage through vibration or any other physical means. Examples of suitable protection methods include bollards, fender posts, guardrails, etc.

Where the meter is located in residential driveways or walkway areas, it shall be mounted to have reasonable protection from damage. (Note: Reference 759B for bollard construction, if used.)

On a service pole, post, or pedestal, the meter shall be mounted to have reasonable protection from damage. Metering facilities for Customers shall not be installed on a Company pole.

7.1.4 Violations

Any Customer or Contractor wiring to a meter or service location that is not approved by the Company is done at its own risk. Corrections of such violations shall be at the Customer's or Contractor's expense.

7.1.5 Security of Unmetered Wiring

The Company will seal all meters and meter facilities on the Customer's premises.

Wireways, cabinets, equipment enclosures and conduit bodies are not permitted where access to the unmetered conductors is not required. Conduit sweeps are the appropriate means of routing where orthogonal turns are required. Where unavoidable situations require the use of wireways, cabinets, equipment enclosures or conduit fittings for such routing, written permission from the company is required and provisions will be included for the Company's lock or seal.

Certain situations require access to unmetered conductors. This may include wireways that supply multiple meters or disconnects. All such wireways, cabinets, equipment enclosures and conduit fittings containing unmetered conductors of any voltage shall be made secure by a Company seal or lock before the service will be energized.

The breaking of seals or tampering with meters or unmetered wiring by unauthorized persons is prohibited. Attention is called to the criminal laws in the states where service is rendered, which make such unauthorized tampering a misdemeanor punishable by fine or imprisonment, or both.

7.1.6 Taps Ahead of Metering

Any tap made ahead of the main service billing meter(s), for life safety systems, control power for utilization equipment, etc. shall be specifically approved by the Company and shall be metered. Customer designated life safety system metering, in most cases, will be transformer rated due to NEC requirements for the continuous duty of life safety systems. Consult the Company for specific guidance.

Exception: Control power for the main circuit breaker operation only shall be permitted to be unmetered.

7.1.7 Group Metering

Where two or more meters are to be installed, all shall be grouped at one location. Prior to the Company setting the meters, each meter position shall be permanently marked by the Customer to clearly identify the space or apartment to which it is connected.

Where the Customer desires to provide either a meter center (multi-socket panel base assembly) or a pedestal style metering assembly, they must be approved by the Company prior to installation. See [Section 7.2](#) for specifications.

Meter centers and metering assemblies are limited to either 120/240V or 208Y/120V or 277/480V or 480Y/277V, with individual meters rated for either 100, 150, 200 or 320 A.

Refer to [Section 4.5.7.5](#) for buildings requiring multiple meter locations.

7.1.8 Shared Metering (for NY only)

In a building where service is supplied to individual tenants, no tenant's service meter shall register utility service outside of the tenant's dwelling. The house loads require a separate meter. The house load is that which is common to the property such as halls, entryways, outdoor lighting, building appliances, etc. and under the property owner's management. The Company shall be consulted in each case where shared metering has been determined for acceptable options in accordance with public service law.

7.2 Meter Applications and Requirements 600V and Less

The following tables are the Company's specified metering applications and requirements for services 600V and less. All services are subject to the limitations of [Section 3.7.1](#).

Table 7.2-1: Self-Contained and Transformer-Rated Meter Applications

Note	Metered Service Type	Metered Service Voltage	# Phases	# Wires	Hot / Cold Sequence	Figure #
400 A and Below self-contained meter applications						
(A), (B)	Single Meter Res / Comm	120/240 120/208	1	3	Hot	7.3-1 , 7.3-2 , or 7.3-3
(A), (C)	2-6 gang Res / Comm	120/240	1	3	Hot	7.3-6 or 7.3-9
(A), (C), (D)	> 6 Meters Res / Comm	120/240 120/208	1	3	Note (D)	7.3-8
	Network	120/208	1	3	Cold	7.3-1 or 7.3-8 ; 7.3-10
(A)	Commercial - Single Meter	277/480	1	3	Cold	7.3-1
(A)	Commercial	208Y/120	3	4	Hot	7.3-4 or 7.3-5 , 7.4.1-1
(A)	Commercial Network - Single Meter	208Y/120	3	4	Cold	7.3-4 or 7.3-5 ; 7.3-10
(A)	Commercial	480Y/277	3	4	Cold	7.3-4 or 7.3-5 , 7.4.1-1 ; 7.3-10
(A), (C)	2-6 gang, >6 Commercial	480Y/277	3	4	Cold	7.3-8 ; 7.3-10
400 A and above transformer-rated meter applications; Company supplies meter socket enclosure						
400 A Only	Residential	120/240	1	3	Hot	7.4.1-1 , 7.4.1-3
	Commercial	208Y/120	3	4	Hot	7.4.1-1 , 7.4.1-2 or 7.4.1-3
	Commercial	480Y/277	3	4	Hot	7.4.1-1 , 7.4.1-2 or 7.4.1-3
(E)	Commercial – Network	208Y/120 480Y/277	3	4	Cold	See ESB 757
(F)	Fire Pumps	All Standard	1 & 3	3 or 4	Hot	7.4.1-1 , 7.4.1-2 or 7.4.1-3

Notes to Table 7.2-1:

- (A) A 400 A service with a class 320 meter and socket enclosure is limited to 320 continuous amperes load capacity - See Table 7.2-6 for rating requirements of service.
- (B) Where a non-standard 120V, 2-wire, 30 A service is maintained, use 240V, 3-wire, 100 A service and use 2-wire for load connection.
- (C) The metered service ratings in this table are the ratings of the occupancy that is being metered. This is not the rating of the service equipment or conductors supplying the overall premise.
- (D) Each individual meter is hot sequence. The overall meter center is cold sequence, with main service equipment to isolate the entire meter grouping or meter center.
- (E) For Commercial Network service above 800 A, consult the company.
- (F) See Sections 4.1.2 and 7.1.6. All service sizes shall be transformer rated meters.

Table 7.2-2: Self-Contained Meter Socket Enclosure Requirements

Req.	Self-contained Meter Socket Enclosure Criteria
1	All meter socket enclosures shall have independent test laboratory listing agency label certifying to ANSI/UL 414, ANSI C12.7, NEMA 250, NEMA Publication No. EL-17, and NFPA 70 (NEC).
2	All meter socket enclosures shall be ringless and individual covers must have a hasp provision for the Company's seal.
3	All meter socket enclosures shall be outdoor NEMA 3R rated and withstand the ambient and environmental conditions where located. Meter facilities shall be protected from dust, moisture, corrosion, etc. (Some extreme conditions may require a minimum NEMA 4X rated enclosure.)
4	Overhead types shall have hub opening at top for top entry in meter socket or central wiring space of ganged sockets.
5	All meter socket enclosures shall have adequate continuous duty and short circuit withstand ratings applicable for the service connection. Refer to Section 5 and Section 9 .
6	Jaw assembly shall permit use of "Mylar plastic disconnect sleeves" being applied over the blades of the watt-hour meter without cutting or mutilation of the insulator material.
7	100 A and 150 A rated meter socket jaw assemblies shall be compatible with Class 200 rated watt-hour meters.
8	Neutral position shall be bonded to the meter socket enclosure.
9	For meter socket enclosures 200A and greater, bolted or lay-in type terminals and terminal blocks shall have Allen or hex head terminal screws rated for 150 in-lbs tightening torque minimum.
10	Underground direct –buried (bottom entry) types and central wiring space of ganged types shall have 3/8 in diameter stud terminals capable of pulling tensions up to 400 lbs force. <ul style="list-style-type: none"> ✓ The Customer shall install crimp type or approved spring-type compression connectors. Mechanical (bolted) connectors are not acceptable. ✓ Parallel conductors (2 maximum) attached to stud terminals shall be terminated with stackable crimp type compression connectors (or spacers approved for the purpose). ✓ Completed connection requires two threads of the stud exposed.
11	Connector temperature rating is preferred at 90 degrees C and insulation material to be rated 600V and arc track resistant.
12	The meter socket enclosure meets the wire bending requirements within the enclosure and at terminations according to the NEC.
13	A manual, single-handled bypass lever with locking jaw and safety arc shield is required for all commercial and 320 A class residential applications. Residential 200 A and less shall not have a bypass device.
14	Unused meter socket positions shall have individual meter closing plates designed to guard exposed live parts.
15	See Table 7.2-4 for number of meter terminals by service voltage. Any 5 th meter terminal is located in the 9:00 o'clock position and connected to the neutral.
16	Meter socket enclosures shall have a minimum short-circuit withstand rating of 10,000 amperes RMS symmetrical at 300V AC. The exceptions are 200 and 320 A-rated single or three-phase meter socket enclosures having short circuit ratings based on the use of an overcurrent protective device on a circuit capable of delivering not more than shown in Table 7.2-3 .

Table 7.2-3: Meter Socket Enclosure Minimum Short Circuit Withstand Capability

kAIC SYM, MAX	MAX OVERCURRENT PROTECTION (A)	VOLTS MAX		kAIC SYM, MAX	MAX. OVERCURRENT PROTECTION (A)	VOLTS MAX
200	200 CLASS J or T FUZE	600		25	100 CIRCUIT BREAKER	240
100	400 CLASS J or T FUZE	600		22	1 ph. 125 CIRCUIT BREAKER	240
100	100 CLASS RK5 FUZE	600		18	200 CIRCUIT BREAKER	240
50	600 CLASS T (300V) FUZE	300		14	ANY CIRCUIT BREAKER	600
42	200 CLASS RK1 FUZE	480				

Table 7.2-4: Number of Terminals for Self-Contained Meter Enclosures by Service Voltage

Service Voltage	Number of Phases	Number of Meter Terminals	Meter Form
120/240	1	4	2S
120/208	1	5*	12S
277/480	1	5*	12S
208Y/120	3	7	16S
480Y/277	3	7	16S
*5th terminal is to be at the nine o'clock position.			

Table 7.2-5: General Self-Contained Meter Socket Enclosure Installation Responsibilities**The Company will:**

- ✓ Designate Service and Meter Locations.
- ✓ Furnish and install service drop conductors to the point of connection and make final connection, except as permitted under [Section 4.2.6](#) for residential overhead service upgrade projects.
- ✓ Install the meter.

Customer will:

- ✓ Furnish and install the service entrance conductors and equipment in accordance with the requirements of the National Electrical Code and the Company.
- ✓ If dissimilar metals are present in the installation, manufacturer recommendations shall be followed.
- ✓ Install expansion joint in underground conduit according to NEC Article 300 for underground served meter socket enclosure.
- ✓ Make connections in meter socket enclosure.
- ✓ Use approved compression connectors on stud-type underground line connections for URD type meter socket enclosure.
- ✓ Install the meter socket enclosure on approved support according to [Section 7.7](#).
- ✓ Obtain an electrical inspection certificate from a recognized electrical inspection authority.

Table 7.2-6: 320 A Meter Socket Applications

Those applicants or existing Customers applying for 400 A service at a delivery voltage of 120/240, 208Y/120 or 480/277V that propose to install a self-contained 320 A meter socket enclosure, shall meet the following criteria:

- ✓ Group the Class 320-meter socket enclosure with an 80% derated main circuit breaker service equipment.
- ✓ Demonstrate as part of the municipal or third-party inspection approval that the load side capacity is not more than 320 A continuous (see NEC Article 220).
- ✓ Customer designs resulting in higher calculated peak load current or using 100% rated main circuit breaker or fuses greater than 320 A will require an instrument transformer metered service.
- ✓ Should the Customer load exceed the rating of a 320 A meter socket enclosure, the Customer shall be required to install transformer rated metering. It is recommended that the Customer reserve space for a future instrument transformer meter cabinet.
- ✓ All 480V class self-contained metering installations shall be cold sequenced.

Note: In all cases, the Company reserves the sole right to specify the final metering configuration based on the Customer's load characteristics and Good Utility Practice.

7.3 Self-Contained Meter Socket Installations

Meter socket enclosures shall not be used as junction boxes or wireways for splices or taps. Caution: Inhibiting grease shall not be applied on meter socket jaws or meter blades. The Customer shall consult with the Company prior to meter socket enclosure installation when considering a meter installation using other than the preferred wiring configuration. The following illustrations are typical arrangements required for the applications and requirements specified in [Section 7.2](#).

Extension devices inserted into the meter socket for the purpose of acting as a transfer switch or additional service disconnect are not allowed by the Company, as they do not meet various requirements of this bulletin. See [Section 7.2](#), [Section 7.3](#), and [Section 11.2.3](#)

Commercial, self-contained meter socket enclosures and residential 320 A self-contained meter socket enclosures shall include a manual bypass lever to allow safe change/removal of meters without disrupting service. All non-residential meters, including, but not limited to cable TV, Cell towers, Traffic signal

meters and any house/ common area meters for multiple occupancy residential/apartment buildings are also considered as commercial meters, and, therefore, shall include bypass levers. Horn bypasses may not be used as a substitute to a lever bypass. The wiring shall not interfere with operation of the by-pass lever.

Second services or additional metered electric services to residential parcels, where allowed by the Company and which serve garages, boat houses, barns and related structures which are deemed “accessory to the residence” do not require lever bypass devices within the meter socket enclosure.

For metered service pedestal serving a mobile home underground, see [Figure 7.3-7](#).

7.4 Transformer-Rated Metering 600 V and Less, 400 A and Above

7.4.1 Instrument Transformers and Enclosures

The Company will specify and furnish the quantity and type of all current and voltage transformers for revenue metering. The Customer shall install all instrument transformers except those for pad-mounted metering. Enclosures shall be approved by the Company but furnished and installed by the Customer. All transformer enclosures must have facilities for Company locks. Instrument transformer cabinets shall not be used as junction boxes or for branch circuit wireways. The entry and exit wiring method for metering transformer cabinets are from the side not the top or bottom. The Customer shall consult with the Company prior to transformer-rated meter cabinet installation when considering a meter installation. In some cases, the Company may choose to supply the instrument transformers to be installed by the switchgear manufacturer.

The premise wiring system connection of the grounding electrode conductor to the grounded service conductor shall not be made in or on the line side of the CT cabinet. Additionally, the grounding electrode conductor shall not pass through the CT cabinet. An equipment grounding conductor, sized in accordance with the NEC, shall be extended from the main service equipment and bonded to the CT cabinet’s grounding stud.

The Company will determine whether window or bar type CT’s are used.

Refer to [Figure 7.4.1-1a](#), [Figure 7.4.1-1b](#), [Figure 7.4.1-2](#), and [Figure 7.4.1-3](#) for typical transformer-rated metering arrangements required for the applications.

For network services, see ESB 757.

7.4.2 Meter Socket Enclosure

The Company will furnish meter socket enclosure for use with instrument transformers. Meter socket enclosures shall be installed by the Customer at the Company’s specified location and wired by the Company. Where the metering is on a pad-mounted transformer, the Company will both install and wire the meter socket enclosure.

7.4.3 Sequence for Transformer-Rated Metering

All metering equipment shall be installed on the line side of the service disconnecting means (Hot Sequence) with the exception of network services. Network services shall have metering equipment installed on the load side of the service disconnecting means (Cold Sequence).

7.4.4 Instrument Transformer Secondaries

The Customer will furnish and install a 1-1/2 inch (41) rigid galvanized steel conduit between the instrument transformer enclosure and the meter socket enclosure which shall be in the same location within sight. The use of conduit body fittings (condulets) with removable covers is not acceptable. The maximum distance between the instrument transformers and the meter shall be 50 feet. Secondary wiring will be furnished and installed by the Company.

7.4.5 Pad-mounted Transformer Service Metering

At the Company's option where a single Customer is supplied from a 300 kVA or larger pad-mounted transformer, bushing current transformers will be used. The meter socket enclosure will be mounted on the outside of the secondary voltage compartment of the pad-mounted transformer. If multiple meters are anticipated at any time, pad-mounted transformer service metering shall not be utilized.

7.4.6 Metal-Enclosed Free-Standing Service Cubicles Rated 600 V or Less (Secondary Voltage Installations)

7.4.6.1 General

The Customer shall provide the Company with equipment specifications prior to ordering any equipment. All components of equipment shall conform to the latest editions of all applicable ICEA & ANSI standards, and the Company recommends that all equipment be certified and approved by a laboratory testing organization such as UL, ETL, CSA, etc.

7.4.6.2 Metering Sequence

Refer to [Section 2.0](#) for the Definitions of Cold Sequence and Hot Sequence, as well as [Section 7.4.3](#) and see [Figure 7.4.6.2-1](#).

7.4.6.3 Unmetered Supply Conductors

Compartments enclosing unmetered supply conductors shall be accessible through hinged doors or removable panels provided with hardware for the installation of locks as specified by the Company.

7.4.6.4 Meter Location

A meter location shall be provided that is large enough for mounting a meter socket enclosure supplied by the Company. The meter socket enclosure shall be installed at the location assigned by the Company, as near as practical to the instrument transformers. The maximum distance between meter and instrument transformers shall not exceed 50 feet. A continuous run of rigid metal conduit shall be provided by the Customer between the meter socket enclosure and the instrument transformers.

7.4.6.5 Customer's Auxiliary Equipment

The connection of the Customer's auxiliary transformer for heat, light and receptacle(s) installed at the meter panel location and elsewhere within the Customer's switchgear, shall be on the load side of the Company's instrument transformers.

7.4.6.6 Metering Transformer Equipment Compartment

A separate properly barriered compartment, completely isolated within the cubicle, shall be provided for the installation of current and voltage transformers of a type and rating as specified and furnished by the Company. The compartment shall be designed with manufacturer provided mounting provisions for the metering transformers. The design shall allow for each transformer to be readily removed or changed without disturbing the others after installation. (See [Figure 7.4.6.6-1](#).) The Customer shall extend the neutral bus to the Metering Transformer Equipment Compartment. Provisions shall be provided for the Company's metering neutral connection to this bus.

Where the metering transformer compartment is located in an unheated area, heaters shall be installed in the compartment to prevent condensation. The Customer shall maintain NEC clearances in front of the metering transformer compartment door.

Phase buses shall be mechanically independent of the instrument transformers and the transformers shall be not part of the bus support system. Removable bus bar sections shall be provided by the Customer to permit installation and removal of current transformers. Silicon-bronze bolts and stainless-steel nuts and washers shall be provided by the Customer for connection of the Company's current transformers.

Access to the metering compartment shall be through a hinged door to permit horizontal swing of at least ninety degrees and provided with hardware for locking as specified by the Company. The metering compartment shall be solely accessible by the Company and have a separate lockable door independent from the doors or access panels for the other compartments within the same vertical section. A single vertical door shall not lock the Company from access to the metering section and not lock the Customer from the other compartments.

No equipment other than Company owned metering equipment shall be installed in the compartment.

In general, only within MA, voltage transformers will be supplied for metering services where the supply is 240 V or greater. Primary connections for the voltage transformers shall be made on the supply side of the current transformers. Instrument transformer-rated metering 400 A and greater, below 600 V applications in Upstate NY do not require voltage transformers.

7.5 Metering Above 600 V

Where the service exceeds 600 V, the Customer shall consult the Company. In such cases, the Company will furnish additional information about the metering requirements. See Electric System Bulletins (ESB) 751 for the required process to obtain service over 600 V. Also, reference Company ESB 758 for primary metering transformer compartment requirements within medium voltage rated Customer-owned switchgear, ESB 753 for typical primary meter pole arrangements and ESB 752 for typical outdoor substation metering requirements.

7.6 Metering Pulse Signals

At the Customer's request, the Company will install at the Customer's expense at the point of metering a source of kWh pulses so that the Customer may monitor load/demand for the purpose of load control. Time pulses will not be provided. The Company is not responsible for Customer equipment failure for the loss of pulse signals.

Analog signal provisions are subject to the Company's applicable tariff; consult the Company for application.

7.7 Meter Boards and Supports

7.7.1 Meter Mounting

All meters shall be durably and securely mounted in a true vertical position on a solid, flat surface. Mounting on irregular or non-rigid surfaces could cause a meter socket enclosure to distort.

7.7.2 Meter Mounted on the Exterior of a Building

Where service connection is made to the building, the meter shall be mounted on that building.

The building structure sub-surface may be used and the siding trimmed around the meter without interference of knockouts and meter cover. Under no circumstances shall the meter socket enclosure be mounted directly to the siding.

7.7.3 Meter Mounted on a Free-Standing Support

The Customer shall provide and mount a meter support for each installation. See [Figure 4.1.8-3](#).

Materials acceptable for all installations are:

- (A) ¾ inch marine grade plywood.
- (B) Galvanized steel slotted framing channel (Kindorf, Unistrut, Superstrut, or approved equal) 12-gauge zinc coated steel, with holes, 1½ inch height X ¾ inch width X (length = width of associated meter socket enclosure), two required, one for top, one for bottom. Zinc coated steel bolts ¼ inches in diameter X ¾ inches long with nut and washer, total of four (4) required, two (2) for top, two (2) for bottom of meter socket enclosure.

- (C) 1½ inch thick minimum pressure treated wood with zinc coated lag bolts, two (2) required, one (1) for top, one (1) for bottom of each board secured to structure.
- (D) Masonry or solid brick wall of building with corrosion inhibiting protection applied to the meter enclosure.
- (E) An outdoor manufactured meter pedestal as specified in [Section 7.3](#) is also an approved meter support method.

7.7.4 Meter Installed Interior to a Building

The meter socket enclosure shall be mounted on a painted and/or treated ¾ inch plywood board is acceptable in dry indoor locations. The support shall provide a clear space for mounting the Company’s metering devices. Provision should be made for air circulation behind the meter board to inhibit “dry rot”.

8.0 MOTORS

8.1 General

It is important that the Company be consulted concerning the type of electric service available to ensure correct application (phase and voltage) of the motor or EV chargers to be used. The correct application of motors or EV chargers is the Customer’s responsibility. Motors and EV chargers should be sized to tolerate possible phase voltage unbalance, must be of a type that uses minimum starting current, and must conform to the Company’s requirements and the applicable electrical code as to wiring, kind of equipment, and control devices. Starting current limitations are prescribed for conventional motorized equipment rated in horsepower and air conditioning or heat pump equipment rated in Btu/hr. Similar instantaneous demand limitations are prescribed for EV chargers rated in amperes with a given duration in seconds. Cases not covered in this section shall be referred to the Company.

8.2 Single-Phase Motors

8.2.1 Single-Phase Motor Limitations

The Company strives to maintain reliable and quality electric power for all residences and commercial Customers. Residential and small commercial services are especially sensitive to voltage fluctuations and flicker resulting from motor starting. In some cases, voltage fluctuations resulting from motor starting can have objectionable results to neighboring services. Therefore, the Company provides the following recommendations. Generally, motors larger than 5 HP should be served via a three-phase supply. Reference Table 8.2.1-1 for allowable motors sizes based on circuit voltage.

Table 8.2.1-1: Recommended Limitations for Single-Phase Motors

Service Voltage or Branch Circuit Voltage	Recommended Maximum Horsepower (HP) or Current (Amps)	Max. Starting Current Per Step Max. Four Starts Per Hour	Max. Equiv. Rating of Air Conditioner or Heat Pump Btu/Hr.
120 volts	Motors < 1/2 HP (See Note (A))	50 amperes	10,000
120 volts	Motors 7.5 A to 12 A (See Note (B))	50 amperes	10,000
208 or 240 volts	Motors > 7.5 A	60 amperes for 2 HP motor	20,000

Service Voltage or Branch Circuit Voltage	Recommended Maximum Horsepower (HP) or Current (Amps)	Max. Starting Current Per Step Max. Four Starts Per Hour	Max. Equiv. Rating of Air Conditioner or Heat Pump Btu/Hr.
208 or 240 volts	Motors > 7.5 A	80 amperes for 3 HP motor	25,000
208 or 240 volts	½ HP to 6-1/2 HP	Residential use – Consult Company	40,000
208 or 240 volts	(See Note (C))	Commercial use – 120 amperes for 5 HP to 6.5 HP	

Notes to Table 8.2.1-1:

- (A) Window type air conditioners should not exceed 7.5 A continuous running load and should not exceed four (4) starts per hour.
- (B) Dedicated branch circuit recommended.
- (C) Consult Company before installing motors with ratings of 3 HP or larger.

8.2.2 Maximum Locked-Rotor Currents

Single-phase motors supplied from combined light and power secondary systems shall not have locked-rotor current values in excess of those shown in [Table 8.2.1-1](#). Motors having locked-rotor current values in excess of those shown in the table shall be equipped with starters that will limit the current to the values specified. Domestic laundry equipment with operating cycles and electrical characteristics as currently available are considered acceptable.

Motors that start more than four (4) times per hour are an exception to the above and may cause interference to other Customers. Automatically (frequently) started motors for general use, such as motors for refrigerators, oil burners, and similar devices, shall not have a locked-rotor current exceeding 23 A at 120V or 19 A at 240V. For multi-motored devices arranged for starting of motors one at a time, the locked-rotor current limits shall apply to the individual motors.

8.2.3 Single-Phase Motors on Three-Phase Service

Where multiple single-phase motors are supplied from a three-phase service, the individual units shall be properly balanced across all three (3) phases.

8.3 Three-Phase Motors**8.3.1 Size of Motors**

In order that the proper capacity may be available to supply the load, the Company should be advised of the motors to be installed. In predominantly residential areas, the Company should be consulted before installing three-phase motors with ratings over five (5) horsepower.

8.3.2 Maximum Locked-Rotor Currents

Three-phase motors supplied from a combined light and power secondary system shall not have locked-rotor current values in excess of those shown in [Table 8.3.3-1](#). Starting compensators are ordinarily required for three-phase motors seven and one-half (7½) horsepower and larger. Exceptions to this practice will be allowed to the extent local distribution facilities permit. Motors having current values in excess of those shown in the table shall be equipped with starters, which will limit the current to the values specified. Increment start motors must have not less than a one-half-second intervals between steps.

The Company should be consulted concerning the installation of three-phase motors ten (10) horsepower or larger and must be consulted on motors larger than fifteen (15) horsepower.

8.3.3 Maximum Permitted Starting Current

This table is based on not more than four (4) starts per hour with long periods of continuous operation under maximum load conditions. Consult the Company if these conditions cannot be met.

The maximum starting currents permitted for a three-phase conventional motorized equipment rated in horsepower and for air conditioning or heat pump equipment rated in Btu/Hr. are:

Table 8.3.3-1: Three-Phase Motor Starting Current

Service Voltage	Max. Starting Current Per Step Max. Four Starts Per Hour	Max. Equiv. Rating of Air Conditioner or Heat Pump Btu/Hr.
208V	100 A up to 5 HP motor	40,000
208V	130 A for 7-1/2 HP motor	50,000
208V	160 A to 10 HP motor	75,000
208V	230 A for 15 HP motor	150,000
480V	50 A up to 5 HP motor	40,000
480V	65 A for 7-1/2 HP motor	50,000
480V	80 A for 10 HP motor	75,000
480V	115 A for 15 HP motor	150,000

8.4 Motor Protection

Protective devices shall be installed on the load side of the meter.

8.4.1 Overload Protection

All motors should be properly protected against overload, including overloads caused by low voltage conditions.

8.4.2 Protection Against Single-Phase Operation

Three-phase motors shall be protected against the possibility of the failure of any one phase of the supply circuit. Three overcurrent (overload) units shall be used, one in each phase, unless the motor is protected against single-phase operation by other approved means. It is the Customer's responsibility to protect three-phase motors against the possibility of single-phase operation.

8.4.3 Reverse Phase Protection

On motors for passenger and freight elevators, cranes and hoists, and other equipment where reversal or direction of rotation might cause property damage or injury, approved reverse phase relays together with circuit breakers, or equivalent devices, should be used on all three-phase installations so that the motor circuit will be opened in the event of loss of any phase or phase reversal. The operation of this relay and associated circuit breaker should be instantaneous and should be such that the circuit cannot be re-energized until the normal phase relations are restored.

8.4.4 Undervoltage Protection

Motors that cannot be safely subjected to full voltage at starting, or would start on return of normal voltage after an interruption and endanger life or property, shall be provided with automatic undervoltage protection. Such protective device shall ensure that with either no voltage or undervoltage, the motor will

be disconnected from the line and the starter will be returned to the “off” position. Where continuous operation of motorized equipment is essential, motor controllers should be arranged to allow motors to operate through a transient no voltage condition lasting for ½ second. The Company shall be consulted where problems of this nature may be encountered.

8.5 Motor-Starting Requirements

8.5.1 Objectionable Voltage Variation

Momentary fluctuation of the circuit voltage occurs each time a motor is started on the circuit. Where this effect is pronounced, a visual disturbance or lighting flicker may be observed by the Customer or other Customers served from the same system. In extreme cases, the motor itself may have difficulty starting.

8.5.2 Current Inrush Limitation

To suppress objectionable voltage variations and maintain proper service to the Customer and its neighbors, it is necessary to set maximum permissible limits to the current drawn from the service during each step of a motor-starting operation, based upon the frequency of starts. These limits are designed to cover typical cases and the Company gives no warranty that particular conditions may not later require a change. There may be locations where other inrush or number of starts limitations may be required.

The specific motor-starting current limitations stated in [Section 8.2](#) and [Section 8.3](#) or furnished by the Company indicate the maximum allowable increases in current on the line side of the motor-starting device at any instant during the starting operation.

These limitations do not restrict the total current that can be taken by the motor, but may require that this total be built up gradually, or in steps during starting. Where a step-type starter is used, an appreciable time must be allowed on each step and the current increase of each step shall not exceed the imposed limitation. Closed transition between starting steps is required.

When motors are started in a group instead of individually, the starting current limitations apply to the group and not the individual motors.

8.5.3 Favorable Locations

There are locations on the Company's system where starting currents larger than specified above can be permitted. The Company shall be consulted to determine whether larger starting currents per step will be permitted for a specified installation.

8.5.4 Company Notification of 3 HP Single-Phase and 10 HP Three-Phase Applications

The Company shall be advised before any single-phase motor 3 HP (equivalent 25,000 Btu/Hr.) or larger, or any three-phase motor rated 10 HP (equivalent 75,000 Btu/Hr.) or larger is purchased and/or installed by a Customer. The information to be given the Company shall include:

- (A) Largest HP
- (B) Rated Voltage
- (C) Rated PF
- (D) Is Motor started under load?
- (E) Motor Application (i.e. sawmill, stone crusher, elevator, air conditioner, etc.)
- (F) Single-Phase or Three-Phase
- (G) Locked Rotor indicating Code Letter
- (H) Frequency of Motor starting and inrush current surges

9.0 TRANSFORMER INSTALLATIONS ON CUSTOMER PREMISES

9.1 General

The Company may require installation of its transformers and other line equipment on the Customer's property. Customer shall provide suitable space, vaults, foundations or pads, conduit and enclosures as required by the Company. Customer shall provide satisfactory access at all times to the space, enclosures, or vaults for the Company to install, or remove, operate and maintain its equipment. For further details on access requirements and suitable space, consult the Company and the following Electric System Bulletins for transformer installations in network (ESB 757), UCD (ESB 759B), and URD (ESB 759A) areas. See [Section 3.0](#) and [Section 4.0](#) for service limitations, allocation of service line cost, and service drop requirements.

9.2 Installations

One of the following general transformer installations may be used for services rated below 600V:

9.2.1 Overhead Transformers

9.2.1.1 Recommended Application

- (A) Where the Company's local Electric Power System is overhead primary construction.
- (B) Where the service meets the requirements of Section 3.7.
- (C) Where aesthetics are not of prime concern.
- (D) Where overhead secondary conductor can be properly supported.

9.2.1.2 Company Furnishes

The Company will furnish, install, own and maintain:

- (A) The primary service lateral including transformer pole, transformers, other required equipment, and one overhead service drop.

9.2.1.3 Customer Furnishes

The Customer shall provide:

- (A) Suitable property on which to install the Company's facilities.
- (B) The necessary right-of-way for the Company's facilities.

9.2.2 Outdoor Single-Phase Pad Mounted Transformer

- (A) An outdoor single-phase pad mounted transformer may be necessary where the voltage drop of the underground secondary service lateral would be excessive.

Note: Refer to ESB 759A and ESB 759B for division of responsibilities and installation methods and requirements.

9.2.3 Outdoor Three-Phase Pad Mounted Transformer

Refer to ESB 759A and ESB 759B for division of responsibilities and installation methods and requirements.

9.2.4 Transformer Vault in Non-Network Area

This type of private property installation is generally no longer available in new installations. Transformer vault service will be considered only where there is no other alternative for service, after the Company and Customer have already met on site to design the service connection. ESB 754 covers such transformer vaults, and continued operation and maintenance of existing facilities. Upgrade of any service supplied from a transformer vault requires review by the Company.

9.2.5 Mat and Fence Substation

A Mat and Fence Substation is an outdoor installation that includes a concrete transformer mat (pad), a bank of overhead style transformers located on said mat at ground level, and a surrounding fence to protect the installation.

This type of private property installation is no longer available for new installations. Customers presently served by mat and fence arrangements are responsible for maintenance of a secure fence and a clean, accessible area within the fence, including vegetation prevention. The Customer must periodically inspect the substation. The Customer is ultimately responsible for any and all areas found to be in need of updating or repair, and must assure that those areas are attended to immediately by an OSHA qualified person. It is highly recommended that the substation be de-energized before any work inside the fence is performed. Please contact the Company prior to considering such maintenance.

9.3 Available Fault Current

For equipment rating purposes, the following tables list the maximum fault currents available at the Company's transformer secondary terminals. While the Company purchases transformers per the most recent IEEE Standards, many older transformers with lower impedances are still in service. Therefore, to be conservative, this table reflects short circuits based on those lower impedances, along with an infinite bus on the primary side. Customer motor or parallel generator contributions and Customer service conductor impedances are not included in the calculations presented. Consideration for future load growth and subsequent transformer change-out may require initial installation of service equipment to have a larger fault current interrupting rating to ensure its suitability according to the NEC. Any costs associated with changes to Customer-owned equipment shall be borne by the Customer.

9.3.1 Network Services

Refer to ESB 757.

9.3.2 Single-Phase Transformers

Table 9.3.2-1: Single-Phase Transformers Available Fault Current

kVA 1ϕ Unit Transformer Rating	Amperes RMS Symmetrical 240V
25 & below	10,500
50	13,900
75	20,900
100	27,800
167*	46,400

***Note:** Values are being provided for legacy installations only.

9.3.3 Three-Phase Overhead Transformers

Table 9.3.3-1: Three-Phase Overhead Transformer Available Fault Current

kVA		Amperes Symmetrical Fault Current	
3 - 1 ϕ Units	Total 3 ϕ Bank	208Y/120V	480Y/277V
3-10	30	10,000	----
3-25	75	20,900	10,000
3-50	150	27,800	12,100
3-75	225	41,700	18,100
3-100	300	55,600	24,100
3-167	500	92,600	40,100
3-250*	750	138,800	60,200
3-333*	1,000	----	80,200
3-500*	1,500	----	120,300

***Note:** Values are being provided for legacy installations only.

9.3.4 Three-Phase Pad Mounted Transformers

Table 9.3.4-1: Three-Phase Pad Mounted Transformer Available Fault Current

kVA	Amperes Symmetrical Fault Current	
3 ϕ Units Pad Mounted	208Y/120V	480Y/277V
75	20,900	10,000
150	34,700	15,100
300	69,400	30,100
500	92,600	40,100
750	41,700	18,100
1,000	55,600	24,100
1,500	----	36,100
2,000	----	48,200
2,500	----	60,200

10.0 DISTURBANCES AND POWER QUALITY

10.1 General

Customers with equipment that cause interference on the Company's system affecting other Customers; shall, upon notice from the Company, take immediate remedial measures to avoid such interference.

Customers shall provide any facilities necessary to secure their own equipment against disturbances including, but not limited to, loss of phase, transients, voltage sags or swells, harmonic or carrier frequencies, rapid voltage changes, or phase unbalance, whether originating with their own equipment or elsewhere. These facilities shall be installed on the load side of the Customer's service equipment.

The Company is not responsible for disturbances resulting from weather conditions, acts of God, operations on the Company's system that are within good utility practice, or that may be generated by the operation of other Customer-owned equipment. The Company's goal is to provide a high-quality service, and it will make every effort to work with its Customers to identify and to minimize the effects of these disturbances. If disturbances do occur, the Customer is advised to call the Company's Customer Service Center.

10.2 Motors

All motors connected to the Company's lines shall be of a type that shall have inrush current and other operating characteristics deemed acceptable by the Company. (See Section 8 for recommendations and guides on motors and controllers.)

10.3 Devices with Intermittent High Current

The operation of electric vehicle chargers, home battery storage, large flashing signs over 10 kVA, arc welders, resistance welding machines, arc furnaces, dielectric and induction heaters, electric furnaces and boilers, electric instant water heaters, heat pumps, X-ray equipment, motors connected to variable load machinery, reciprocating compressors, pumps, molding machines, rock crushers and similar apparatus having intermittent flow of large currents sometimes interferes with other users of the electric service and may require special facilities for satisfactory service. The Company in accordance with its applicable tariff may refuse to connect such loads which are considered detrimental to the service of other Customers.

In lieu of such refusal, the Company may require a Customer to install, at its own expense, any necessary corrective equipment in accordance with requirements and specifications of the Company, provided such installation does not conflict with applicable electrical code, and Federal, State, or Municipal law. Alternately, the Company may require a service arrangement, installed at the Customer's cost, that mitigates the disturbance.

10.4 Automatic Reclosing

Where the Company has installed on its facilities equipment for automatic reclosing after an interruption of power supply, it shall be the obligation of the Customer to provide at its expense:

- (A) Adequate protective equipment for all electrical apparatus of the Customer that might be adversely affected by the Company's reclosing equipment, and
- (B) Such equipment as may be required for the prompt disconnection of any apparatus of the Customer that might affect proper functioning of the Company's reclosing equipment.

10.5 Harmonic and Other Distortion

If at any time devices (i.e. carrier frequency systems, SCR controllers, etc.) installed by the Customer are causing harmonics or interference on the electrical system of the Company, Customer, or to any other entity, then upon notice from the Company, it shall be the responsibility of the Customer to install remedial equipment or take such other measures as may be necessary to reduce such interference to a tolerable

level. The latest versions of IEEE Standard 519 shall be followed for tolerable levels for harmonic current and voltage distortion.

10.6 Power Supply to Voltage Sensitive Equipment Computers and Sensitive Equipment

Customers who use computers, microprocessor-controlled equipment, solid state devices, x-ray equipment, or other voltage sensitive electronic equipment should consider the installation of auxiliary devices designed to protect this equipment from power disturbances. These power disturbances may be in the form of voltage sags or swells, temporary loss of power, or any other deviation from normal. The Customer may have to safeguard this equipment by the application of line filters, solid state line-voltage regulators, transient suppressors, isolating transformers, uninterruptible power supply (UPS) systems or motor generators. Utility distribution systems normally operate between certain voltage limits as established by National Standards and state rules. The Company should be contacted for further guidance.

10.7 Isolation Transformer

Where lighting or other reduced-voltage equipment is permitted from existing three-phase, 3-wire, delta non-standard services, isolation transformers are required. The secondaries of these isolation transformers shall be properly grounded. The minimum number of single-phase transformers that may be used to serve the reduced-voltage load on a three-phase, 3-wire service is shown in the following table:

Table 10.7-1: Minimum Number of Single-Phase Transformers to Serve Reduced Voltage Load on a Three-Phase, 3-Wire Service

Reduced-Voltage Load in kW or % of Total Demand on Service (whichever is larger)	Number of Transformers
Less than 5	1
5 to 10 inclusive	2
Over 10	3

The Company should be consulted prior to buying isolation transformers for this type of installation. Since auto-transformers do not provide isolation between primary and secondary windings, they shall not be used on three-phase, 3-wire, ungrounded-delta service except to supply reduced voltage for motor starting. Auto-transformers used to supply other branch circuits shall be supplied only by a grounded system as outlined in the National Electrical Code or of any other applicable code.

10.8 Electric Vehicle (EV) Chargers

To prevent flicker, Customers installing UL 2594 certified Level 2 chargers shall utilize settings that allow the charger to ramp in the charging load. UL 2202 certified DC fast charging equipment presents unique inrush/power quality challenges that require the Company's review. See [Section 3.14](#).

11.0 CUSTOMER-OWNED ELECTRIC SOURCES – INCLUDING STANDBY GENERATORS

11.1 General

Any generating equipment that is or can be connected to any circuit which is, or can be supplied from the Company's distribution system shall meet the requirements of this section. This is to prevent any

unanticipated backfeed of electricity into the Company's system as required by the Company's applicable tariffs.

Any non-residential Customer generation on its premise requires submittal of documentation to the Company in accordance with the Company's applicable tariff prior to installation. Consult the Company for the prescribed forms.

11.2 Emergency and Standby Electric Sources

11.2.1 Compliance Criteria

The Customer shall notify the Company prior to installing non-parallel, standby generating equipment and obtain approval for the method of connection. Where the Customer installs a standby generator for the purpose of supplying all or a part of the load in the event of an interruption in the supply of Company service, the Customer's wiring shall be arranged so that no electrical connection can occur between the Company's service and the Customer's other source of supply. This will require the installation of a double-throw, "break-before-make" transfer switch or similar disconnecting device acceptable to the Company; see [Section 11.2.3](#). This transfer scheme must meet these requirements established by the Company. See [Figure 11.2.1-1](#). Unless required in [Section 11.2.2](#) or [Section 11.2.3](#) residential standby generator installations will not need prior Company approval since the Customer's electrical inspection approval certificate will ensure compliance with these Company specifications and the NEC.

A non-residential Customer utilizing generation shall meet the following requirements if it proposes the installation under the Company's definitions of emergency or standby power system:

- (A) Accepted documentation on file with the Company.
- (B) Stated conditions when the Customer's emergency or standby generator may serve load on its premise for periods of time required by regulation or statute. Otherwise, test periods shall not exceed ten (10) hours per month.
- (C) Maintain a written operating log indicating date, time, hours, and purpose of operation available to the Company upon request.
- (D) Non-compliance will result in billing and installation of generator meter(s) in accordance with the Company's tariff.

11.2.2 Electric Source Type & Installation Method

11.2.2.1 Separately Derived Systems

When an AC generator is installed as a separately derived system, grounding of the neutral conductor shall be in accordance with the National Electrical Code. Separately derived systems require a switched neutral conductor in the transfer switch. Figures in this bulletin do not show this system configuration. The Customer is required to maintain safe step and touch voltages when installing a separately derived system in conjunction with the Company's electric service connection. This may require the services of a design professional.

11.2.2.2 Temporary Emergency Connections

To avoid serious risks to utility workers and the general public, Customers without permanently connected transfer systems may temporarily install emergency generators under the following conditions:

- (A) Generator connection is made on the load side of the main disconnect device (i.e. circuit breaker, switch, or fuse block).
- (B) The main disconnect device is tagged in the "open" position after ensuring disconnect is electrically open. The tag shall clearly state "do not operate".
- (C) The Company's meter shall not be accessed.
- (D) Notify the Company when electrical separation cannot be accomplished by the Customer's equipment.

11.2.3 Transfer Systems

11.2.3.1 Service Equipment Rated Transfer Switches

Transfer switches listed and labeled "suitable for use as service equipment" are permitted for use as main service equipment upon prior approval by the Company. All other transfer switches shall be connected on the load side of the main service equipment.

11.2.3.2 Open-Transition Transfer

A double throw switch or contactor using a "break-before-make" sequence shall normally be provided to transfer all ungrounded conductors of an emergency lighting or power load to either the stand-by generator (or other electric source) or the normal supply.

11.2.3.3 Closed Transition and Auto Transfer

These requirements apply to closed transition schemes associated with dual feeder source, standby or emergency generators where the generator will momentarily operate in parallel with the Company's system. This can be accomplished utilizing breakers or an Automatic Transfer Switch (ATS). Generation that is normally in parallel with the Company EPS and wishes to intentionally island, see requirements in ESB 756B/C Section 7.6.14.

- (A) The Customer shall submit for acceptance by the Company three copies of the single line, specifications, complete vendor prints, relay settings and a description of operation of the system.
- (B) Requirements for Closed Transition Switching:
 - (1) Closed transition switching shall occur within fifteen (15) cycles.
 - (2) Closed transition switching shall not be initiated until 5 minutes of healthy utility voltage has been present. Healthy voltage shall be defined as within the range of 95 -105% of nominal.
 - (3) Once the parallel is made, a transfer failure relay shall monitor the utility and generator breaker to ensure the transfer operation has been completed. If the transfer has not been completed within thirty (30) cycles, the transfer failure relay shall trip the generator breaker. For ATS installations, the transfer failure relay shall monitor the switch contacts.
 - (4) The settings for paralleling the generator to the Company's system shall not exceed the values listed in Table 11.2.3.3-1. All devices that perform paralleling shall be utility grade, that is, they must meet the requirements of IEEE C37.90.1, 2, and 3.
 - (5) The system shall be designed such that loss of the utility source initiates an open transfer.
 - (6) The system shall allow functional testing of the various operating and failure modes outlined in the description of operation.
 - (7) The Company reserves the right to witness functional testing of the transfer scheme, including failure modes. In these cases, it shall be the responsibility of the Customer to demonstrate proper operation and functional testing.
- (C) Exercising Generator:
 - (1) If there is no load bank, and it is the intention of the Customer to exercise the generator in parallel with the Company for an extended period of time (> 30 cycles), the generator shall meet the requirements of ESB 756.
 - (2) The Customer can exercise the generator with building load under requirements Items (B)(1) through (B)(6) above and the Company's filed Tariff.

Table 11.2.3.3-1: Relay Settings to Parallel Standby or Emergency Generators with the Company System

Generator Size (kW)	Max. Frequency Difference (Δf , Hz)	Max. Voltage Difference (ΔV , %)	Max. Phase Angle Difference ($\Delta \phi$, degrees)
0-500	0.3	10	20
>500 – 1,500	0.2	5	15
>1,500 – 10,000 or Dual Feeder Source	0.1	3	10

11.2.4 Identification and Clearances

- (A) In accordance with the NEC and [Section 4.9](#), a label shall be placed at the service-entrance equipment that indicates the type and location of on-site standby power sources.
- (B) Customer's on-site generator and fuel storage are often located adjacent to Company pad-mounted transformers for ease in using the same trench to the electrical room. Refer to ESB 759B for the requirements for locating a generator and fuel storage in the proximity of a Company pad-mounted transformer. This design shall be submitted to the Company for approval.

11.3 Parallel Electric Power Production

No Customer or Independent Power Producer (IPP) shall install or operate electric generation (or other electric sources) in parallel with the Company's system without prior notification to and approval by the Company. This includes UL 1741 certified inverters that will be used for standby power to the premise (V2H).

Customers considering the installation of parallel electric power production equipment to supply all or a portion of their electrical energy requirements, and who wish to arrange for, or continue to receive, service from the Company's system for their remaining electrical energy requirements and/or for stand-by service, must consult with the Company regarding the design, installation and operation of such equipment. (See Company's Electric System Bulletin No. 756 and its applicable appendix for additional details.) Precautions must be taken to maintain adequate safety and quality of service to other Customers. Customers wishing to sell electric energy shall call the Company's Customer Service Center. Those Customers having managed accounts shall consult with their Account Manager for the Company's purchase policy.

11.3.1 Inverters

Direct current electric sources may be operated in parallel with the Company's system through a synchronous inverter where its installation will be designed such that a Company system interruption will result in the removal of the inverter from the Company's system. The Customer shall submit specifications for approval by the Company prior to procurement or installation of the inverter. (See Company's Electric System Bulletin No. 756 and its applicable appendix for additional details.)

12.0 UTILIZATION and SPECIAL EQUIPMENT

12.1 Electric Fences

The Company urges extreme care in the selection of an electric fence system. A direct electrical connection to a fence or a connection through resistance, reactance, or lamp bulb, is not permitted without an approved controller. For guidance in safety methods, materials, and equipment to construct electric fences, those interested are referred to U.S. Department of Agriculture, Farmers Bulletin No.

1832 or to qualified experts such as the Department of Agricultural Engineering, Cornell University, Ithaca, New York.

12.2 Signs and Automatically Controlled Lighting

The Company shall be consulted in advance when signs or automatically controlled lighting are to be installed. Flashing signs shall be properly balanced throughout each portion of the flashing cycle.

12.3 Lightning and Surge Protection

When a Customer desires to install its own lightning or surge arrester it shall be connected on the load side of the main service disconnect by and at the expense of the Customer. For protection to be effective, such devices should be connected in conjunction with any applicable codes and approved by the AHJ. The Customer shall be responsible for providing, installing, operating, maintaining, and inspecting any such installations. The Company will not be responsible for damage to a Customer's equipment resulting from voltage surges that may occur on the Customer's wiring.

For services above 600V, lightning or surge arrester installations should be made in accordance with recommendations of the Company's Engineering Department and the applicable supplements to these specifications.

12.4 Power Factor Correction, Capacitors

Maintenance of high-power factor is of the utmost importance to both Customer and Company in the operation of each of their distribution systems. Company rates are based, in general, on a minimum average power factor. The minimum average power factor value shall be that specified in the Company's applicable rate structure. The Company should be consulted in advance regarding all installations likely to develop low power factors so that such conditions may be rectified by measures adapted to each proposed installation.

Customers are encouraged to maintain a power factor near 95 percent. The use of synchronous motors is desirable since these contribute to good power factor. Where possible, induction motors should be applied so as to operate at, or near, full rating.

12.4.1 Capacitor Installation

A Customer, installing capacitors to improve the power factor of its load, should obtain from the Company the characteristics of the supply system so that the capacitors can be properly applied. Consult the Company prior to procuring and installing power factor correction equipment for Company review and acceptance to assure that service to other Customers will not be adversely affected by the manner in which such equipment is installed and operated.

12.4.2 Static VAR Compensators (SVC)

A Customer, installing static VAR compensators (SVC) to improve its power operating efficiency of its electric system, should obtain from the Company the characteristics of the supply system so that the SVC's can be properly applied. Consult the Company prior to procuring and installing SVC equipment for Company review and acceptance.

12.5 Radio and Television

12.5.1 Transmitting Station, Repeater, or High Frequency Equipment

Before a Customer installs and operates radio or television transmitters, repeater, or other high frequency equipment at a specific location, the Company shall be consulted for information on the type of electric service that will be supplied and the special precautions that must be observed so that the operation of this apparatus will not interfere with electric service to other Customers.

12.5.2 Antennas

Outdoor antennas for radio or television sets shall not be erected over, under or in close proximity to the Company's wires or any other wires carrying electric current, and shall not be attached to the Company's

poles or Customer riser masts. To do so may result in serious accident or damage to equipment. Where practical, antenna conductors shall be installed so as not to cross under open electric conductors. Where proximity to electric conductors of less than 250V cannot be avoided, the clearance shall be at least 2 ft. In all cases, the National Electrical Safety Code conditions shall be met.

12.5.3 Eliminator or Trap

Installation of an eliminator or trap where necessary shall be suitable and shall be installed by the Customer in such manner as to prevent radio, telephone, television, and other interference feeding back into the supply circuit.

12.6 Carrier Current Systems

If a Customer uses building wiring for a carrier current system for remote control of power, communication, signaling, or other purposes, the Customer shall install suitable filter equipment or make other provisions approved by the Company to keep the Company's distribution facilities free from any high-frequency components or carrier currents produced by the Customer's equipment. Consult the Company prior to procuring and installing carrier current system equipment for Company review and acceptance. The Customer is also responsible for correction of any interference caused to other Customers.

13.0 REVISION HISTORY

<u>Version</u>	<u>Date</u>	<u>Description of Revision</u>
1.0	04/20/2010	Initial version of new document superseding all previous revisions of ESB 750 and the Electrical Service Information and Requirements (Green Book)
2.0	01/06/2020	Major revision of all sections.
3.0	01/06/2021	Incorporated July 2020 Errata & Revision
4.0	01/04/2022	Incorporated January 2021 Errata & Revision. Minor revisions to text and figures.
5.0	01/02/2024	Incorporated May 2023 Errata & Revision. Minor revisions to text and figures.
5.1	03/01/2024	Minor numbering updates.
6.0	01/01/2025	Revised for updated National Grid practices, see highlights.

14.0 FIGURES

The Figures that follow are not intended to be used alone and must be used in conjunction with the corresponding text of this publication.

Variations of the arrangement of each Figure may exist.

Certain specifications in these Figures supplement and may exceed standards of safety regarding the Customer's electrical installation set forth in the National Electrical Code (NEC), the National Electrical Safety Code (NESC) and other applicable codes. For any details not included in these Figures, refer to the NEC, NESC, and other Codes, Standards, and references listed in [Section 1.5](#).

Figure 1.5-1: Utility Electric Supply and Premise Wiring Illustration

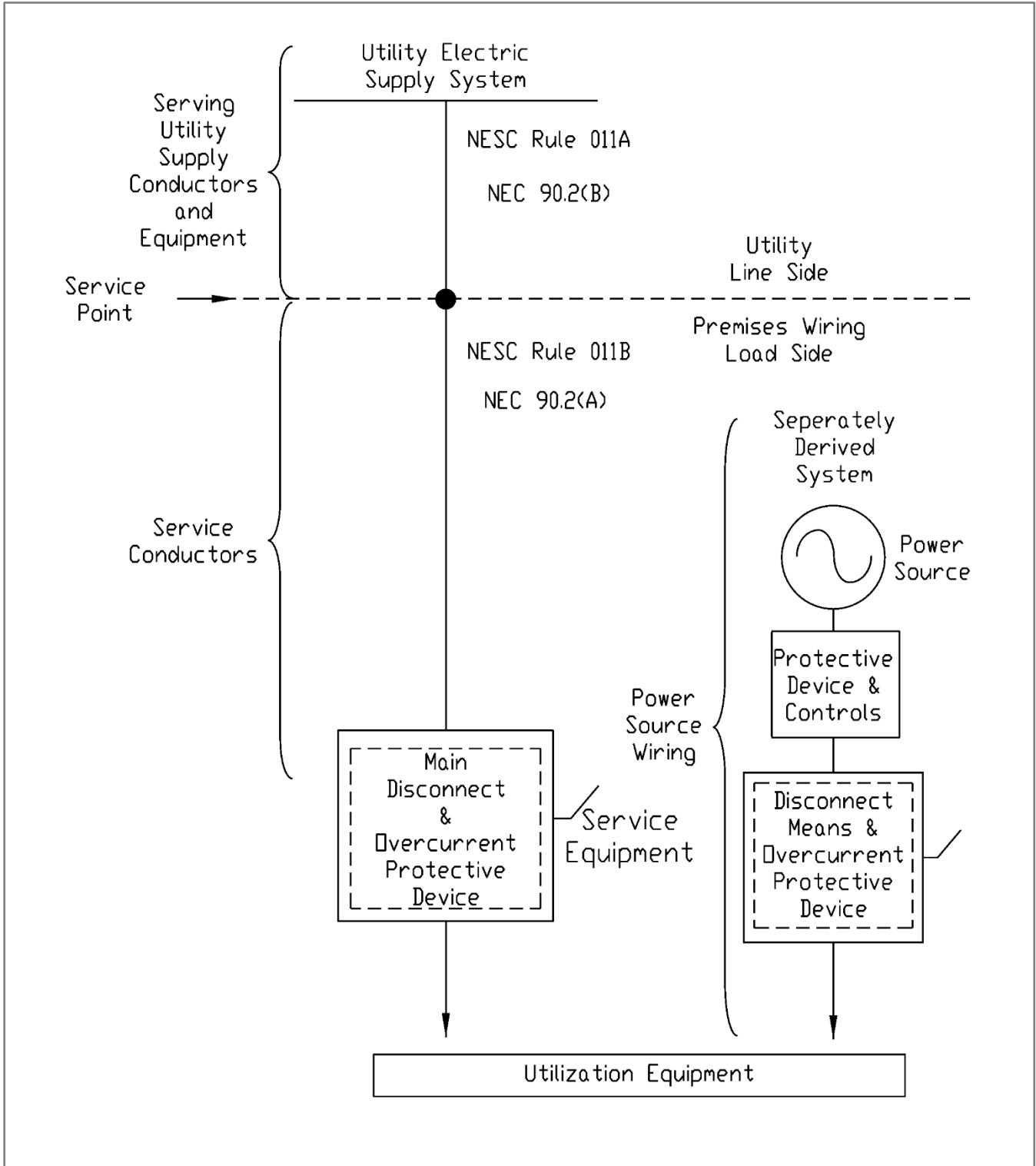

Figure 2-1: Typical Service Installation Diagram Below 600V – Excluding Network

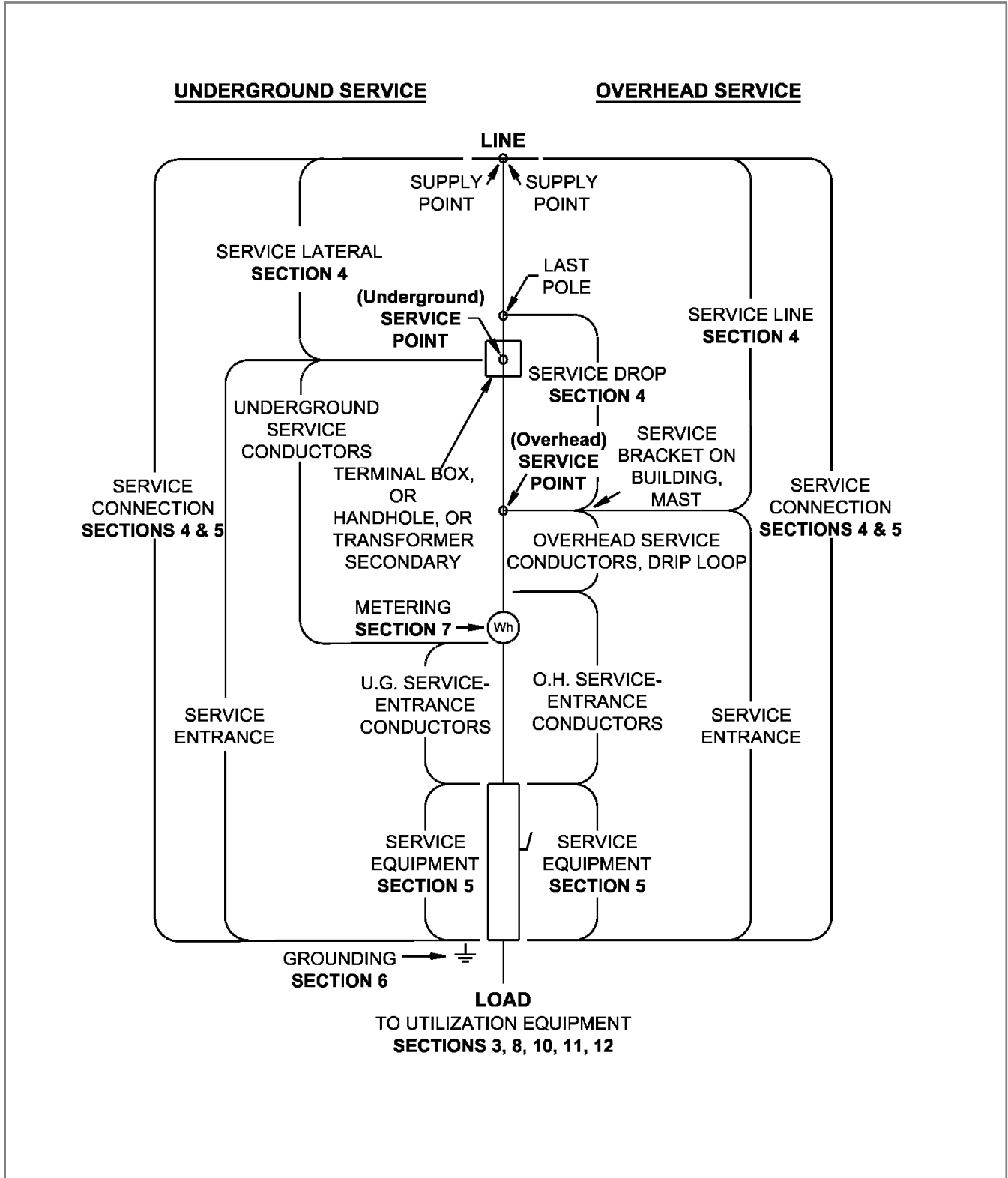

Figure 4.1.8-1: Typical Overhead Service Pole for Permanent or Temporary Service Below 600V

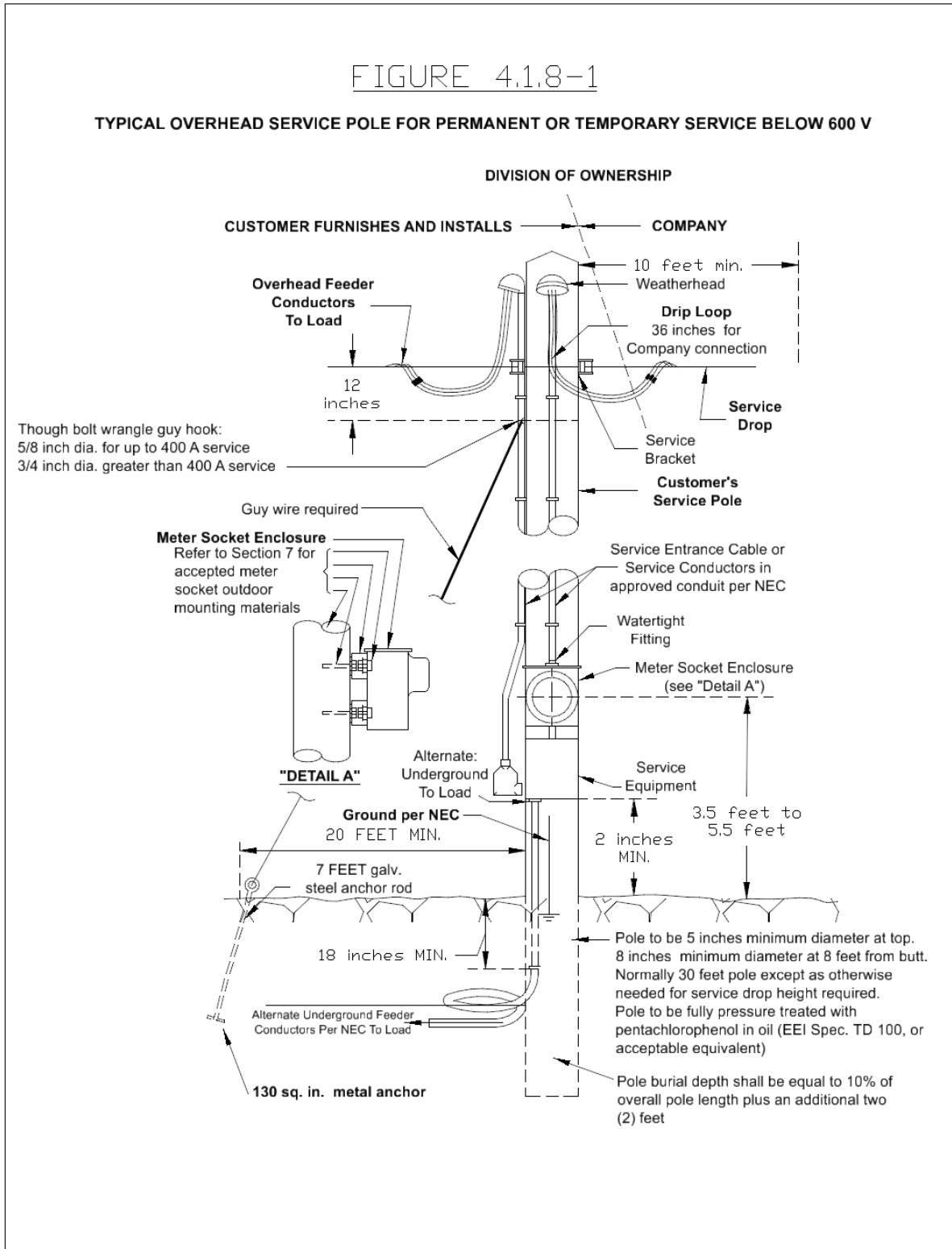

Figure 4.1.8-2: Alternate Temporary Overhead Service Below 600V; Maximum 50' Service Drop Only to be Used in Areas of Pedestrian and Restricted Traffic Only

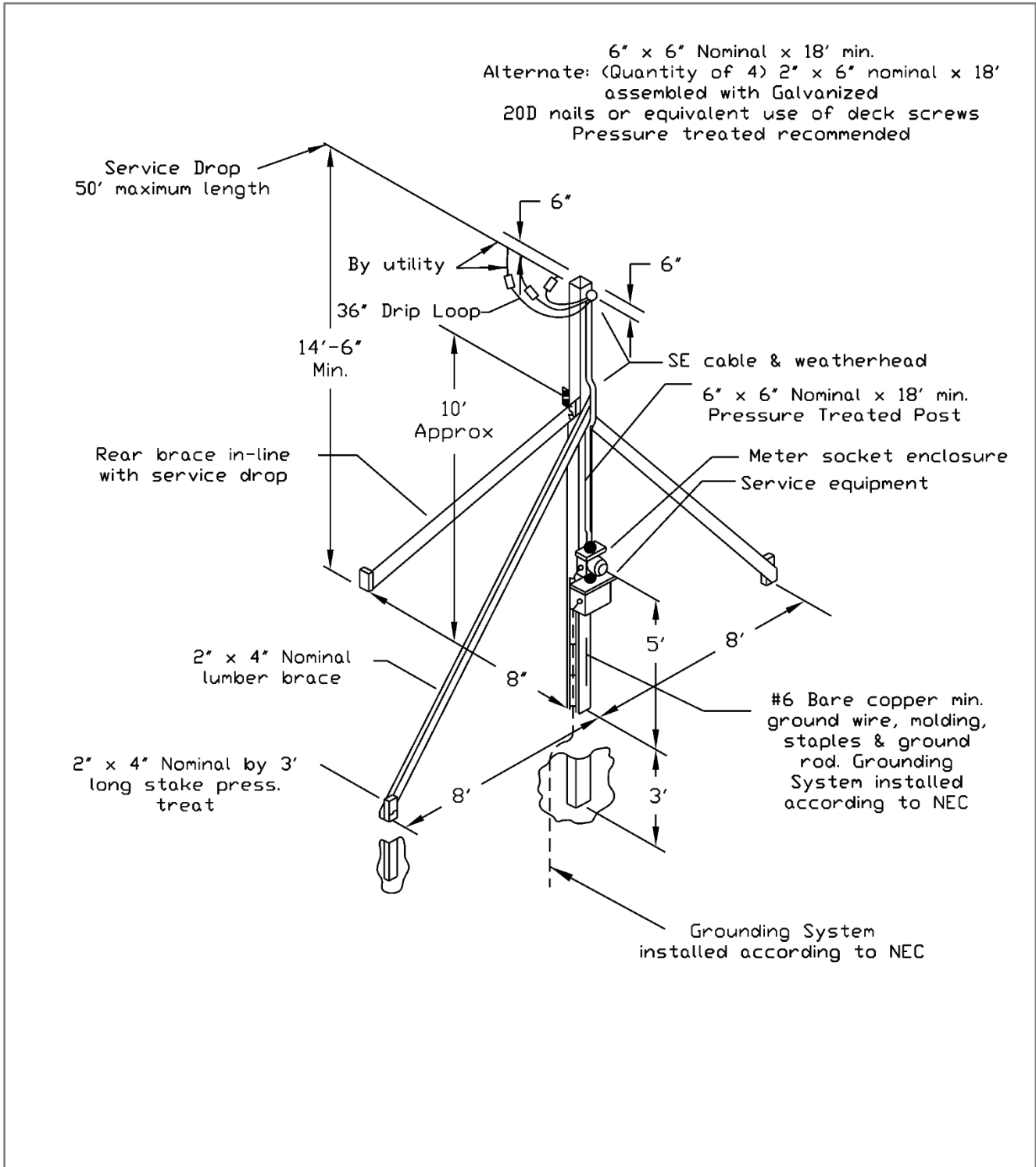
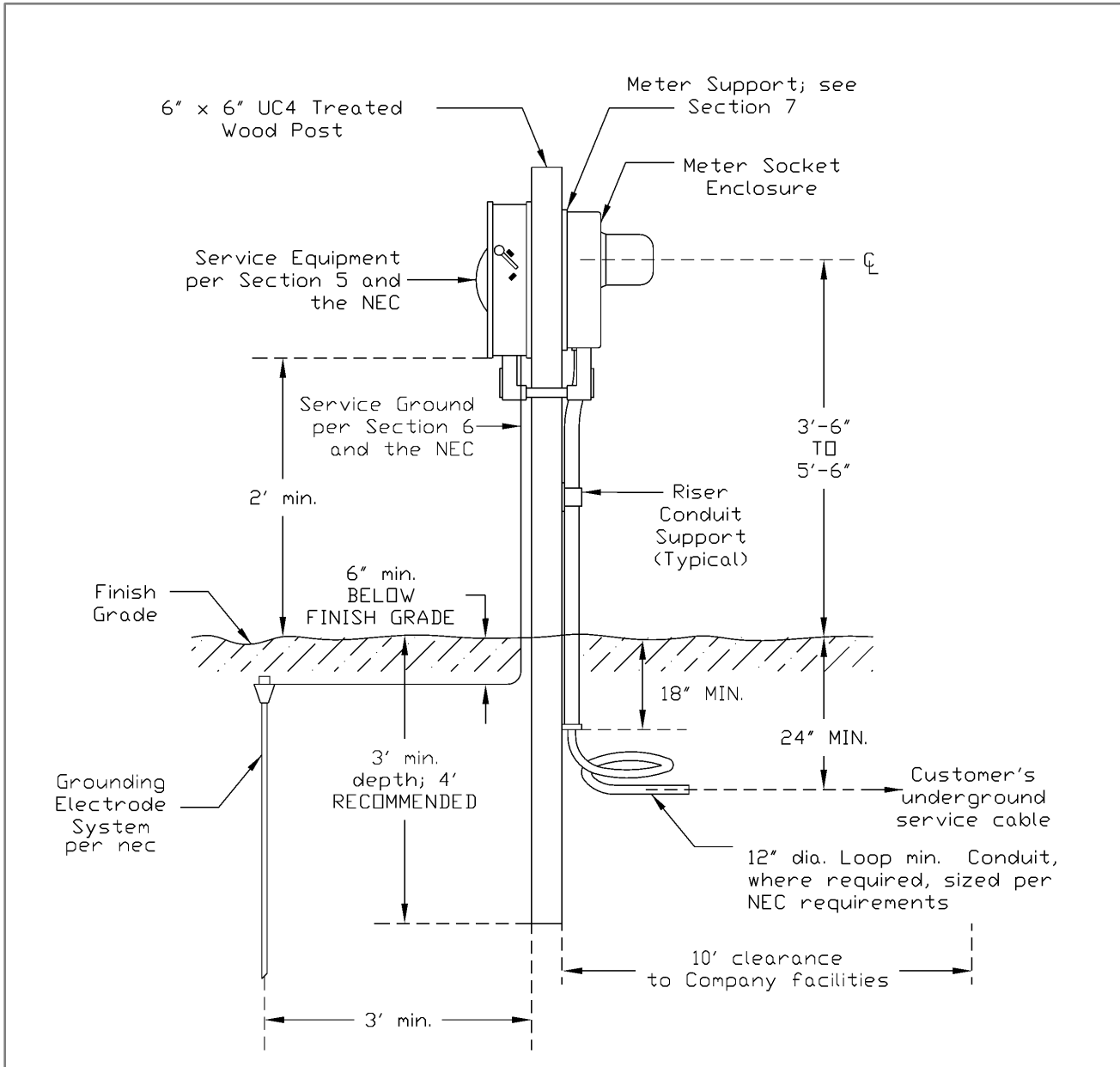

Figure 4.1.8-3: Typical Post Installation for Permanent or Temporary Underground Service



Notes to Figure 4.1.8-3:

- (A) Alternate: Install two (2) 6"x6" wood posts with 3/4" marine grade plywood mounting board. Mount disconnect and meter socket enclosure on same side.
- (B) Rise conduit must be supported between ground and disconnect or meter.
- (C) Depth of burial of conduit shall be minimum 18" below final grade. Depth of burial of direct buried cable shall be minimum 24" below final grade.
- (D) For cold sequence installations, consult the Company.

Figure 4.1.9.1-1: Typical Service to Manufactured and Mobile Homes and Mobile Home Parks

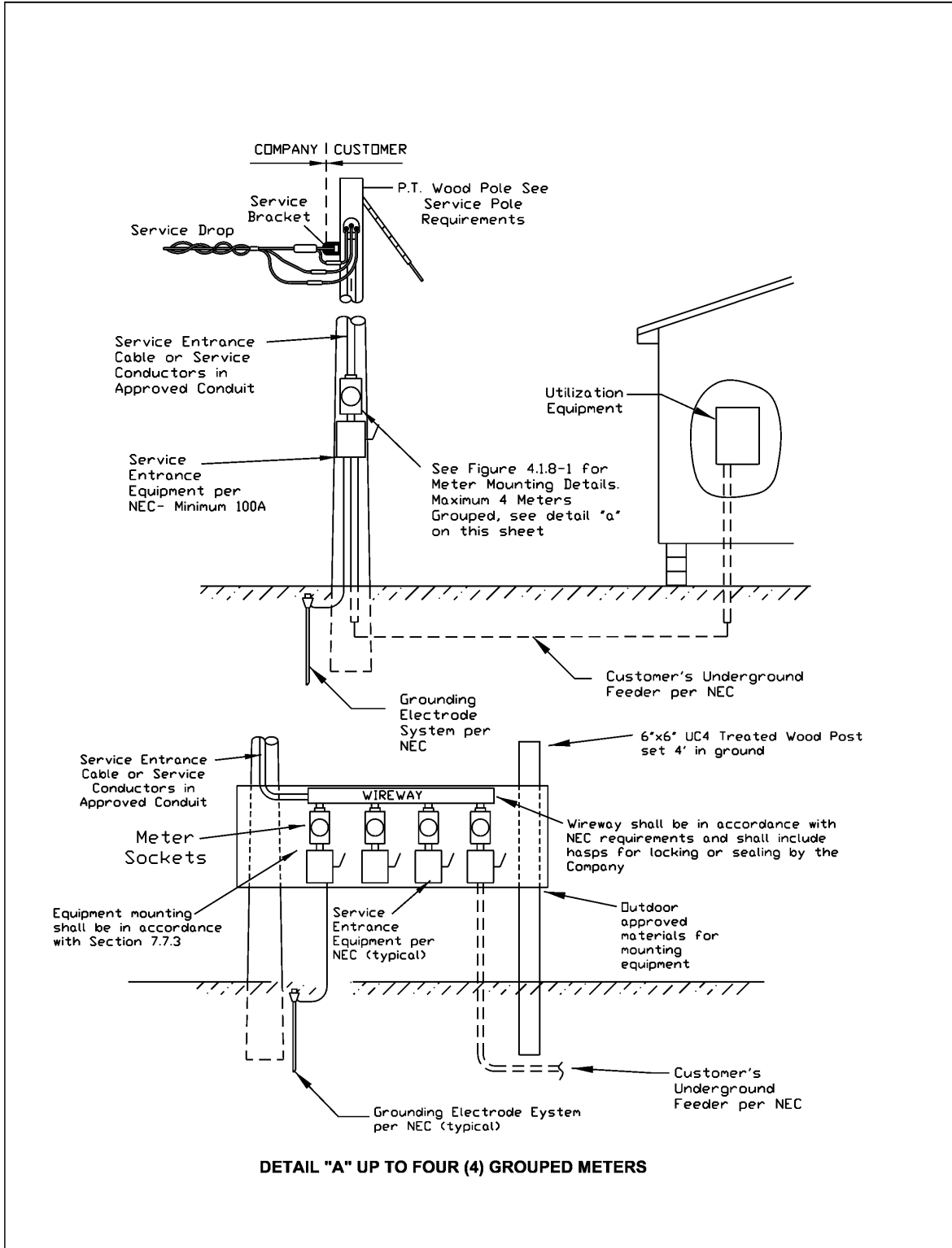

Figure 4.2.1-1: Typical Overhead Service Arrangement Under 600V

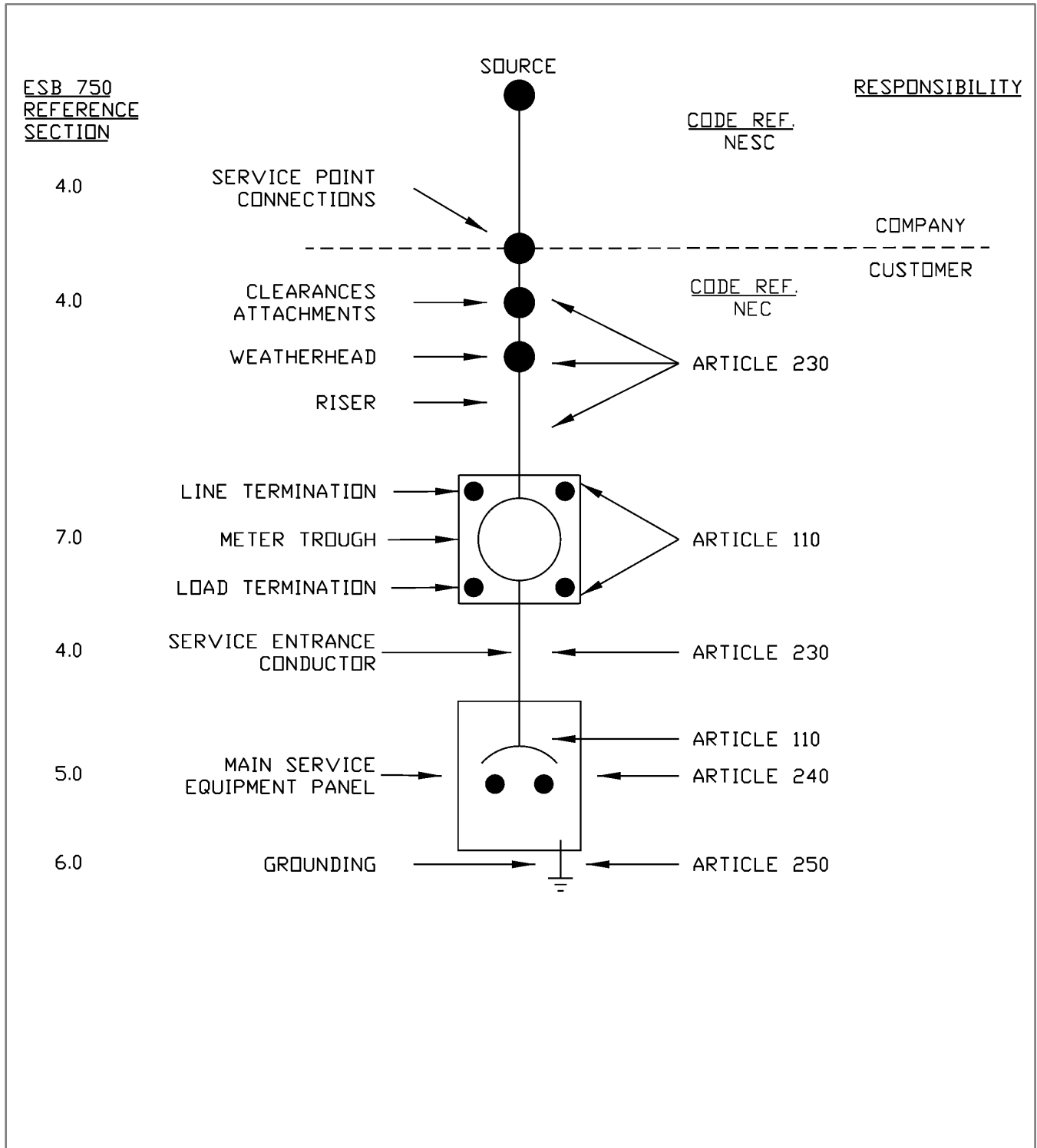
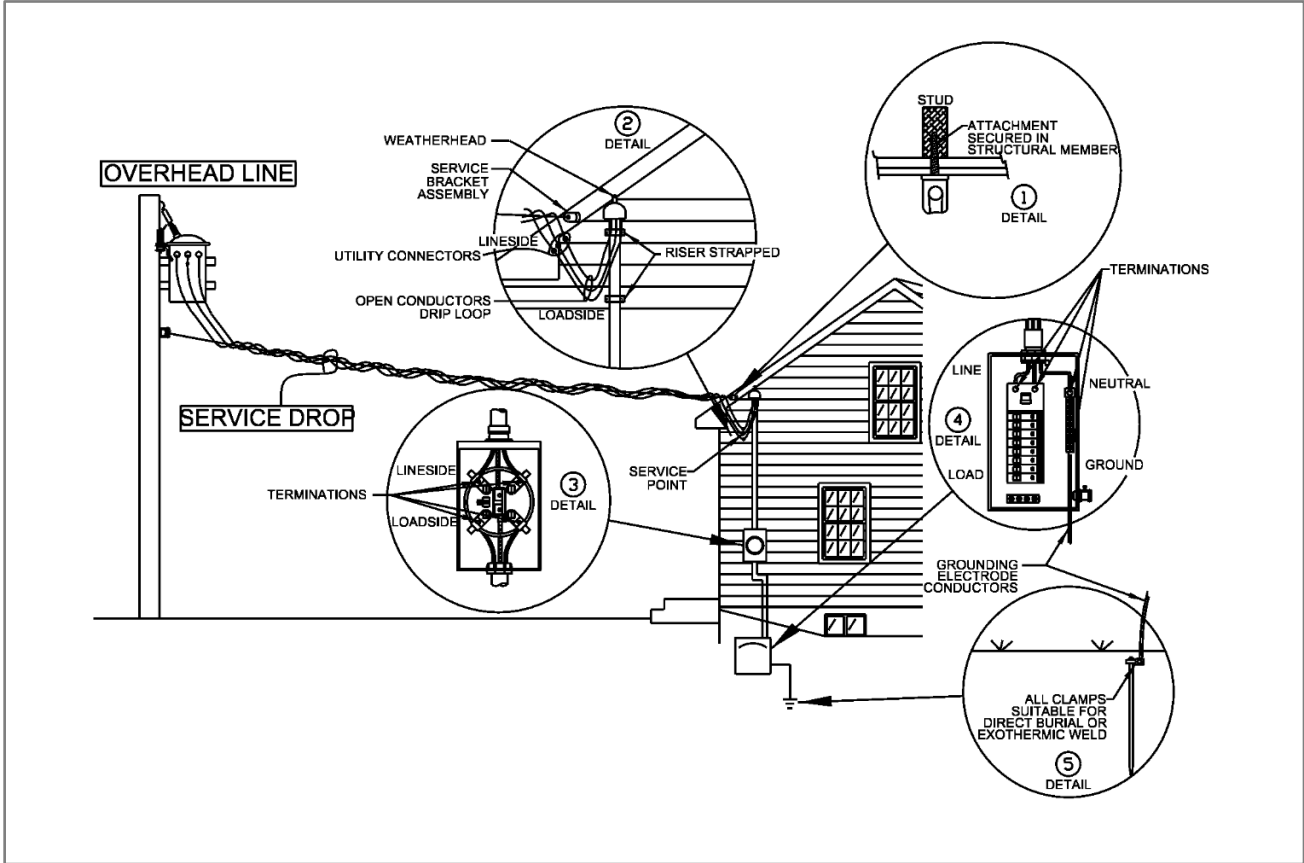

Figure 4.2.2-1: Typical Residential Overhead Service Under 300V and 400 A



Notes to Figure 4.2.2-1:

- (A) Point of Attachment (Detail 1)
 - (1) 600 Volt insulator installed at proper clearance. See [Section 4.2.4](#). Company service drop attachment shall comply with NEC clearances of 12 inches to other attachments.
- (B) Drip Loop (Detail 2)
 - (1) To prevent the entrance of moisture, drip loops shall be formatted on individual conductors. See Section 4.
 - (2) Open conductor's clearances from openings - see [Section 4.2.4.1](#).
- (C) Meter Socket Enclosure (Detail 3)
 - (1) Location, Mounting, and Work Space – see [Section 7.0](#) and Figure 7.1.2-1.
 - (2) Independent Test Laboratory Certification – see [Section 7.2](#).
 - (3) Terminal Connections of Service Conductors in Meter Socket Enclosures – see [Section 7.2](#) and [Section 7.3](#)
- (D) Service Equipment (Detail 4 - Main Disconnecting Means and Overcurrent Protection)
 - (1) Main means to disconnect and protect premise wiring system from overcurrent conditions – see [Section 5.0](#).
 - (2) Service conductors shall be connected to the service disconnecting means. See [Section 4.0](#) and [Section 5.0](#).
- (E) Grounding and Bonding (Detail 5) – The service equipment shall be grounded. See [Section 5.0](#) and [Section 6.0](#) of this Bulletin and Article 250 of the NEC.

Figure 4.2.4.4-1: Overhead Service Attachment and Riser Mast Requirements

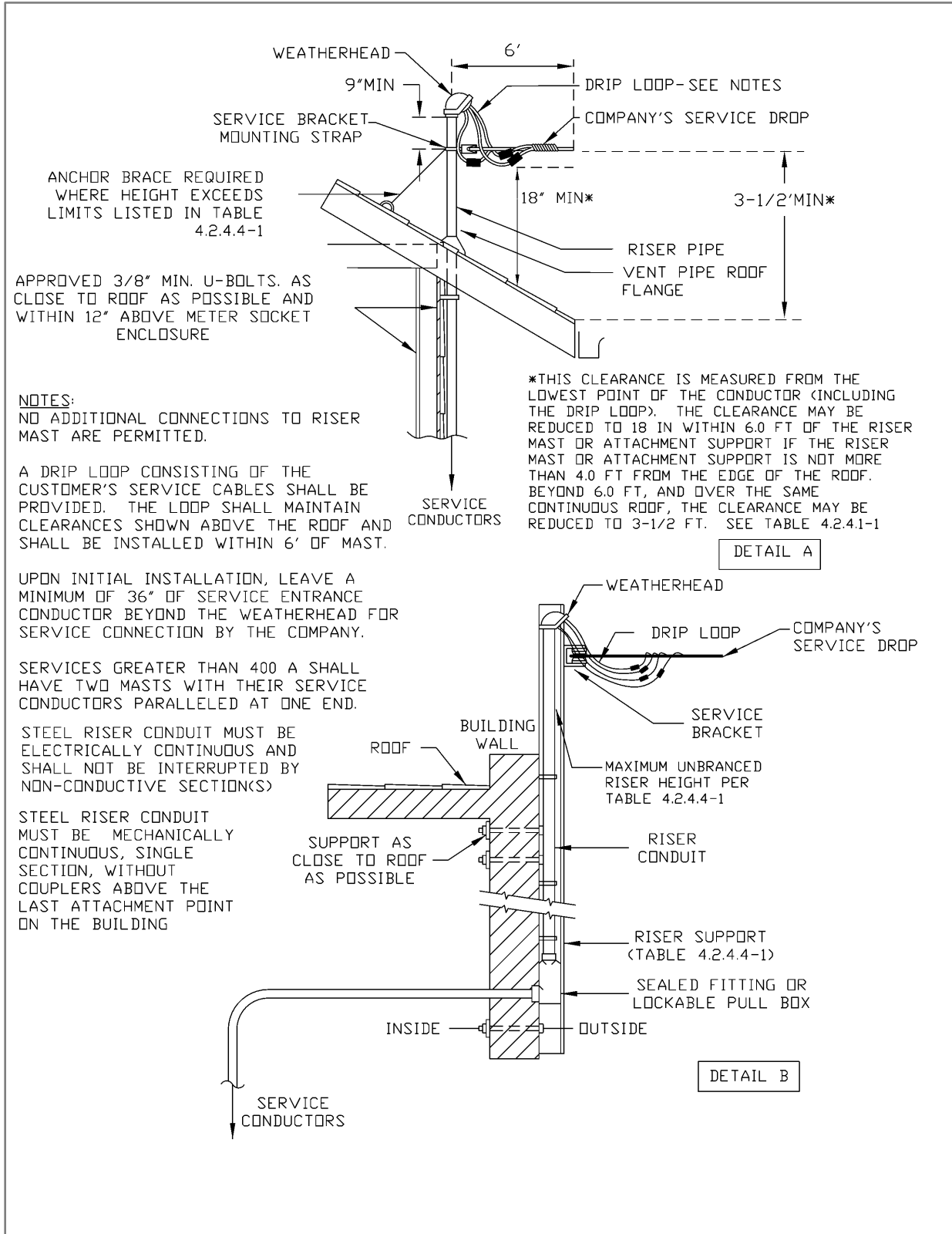

Figure 4.5.1-1: Typical Underground Service Arrangement Under 600V

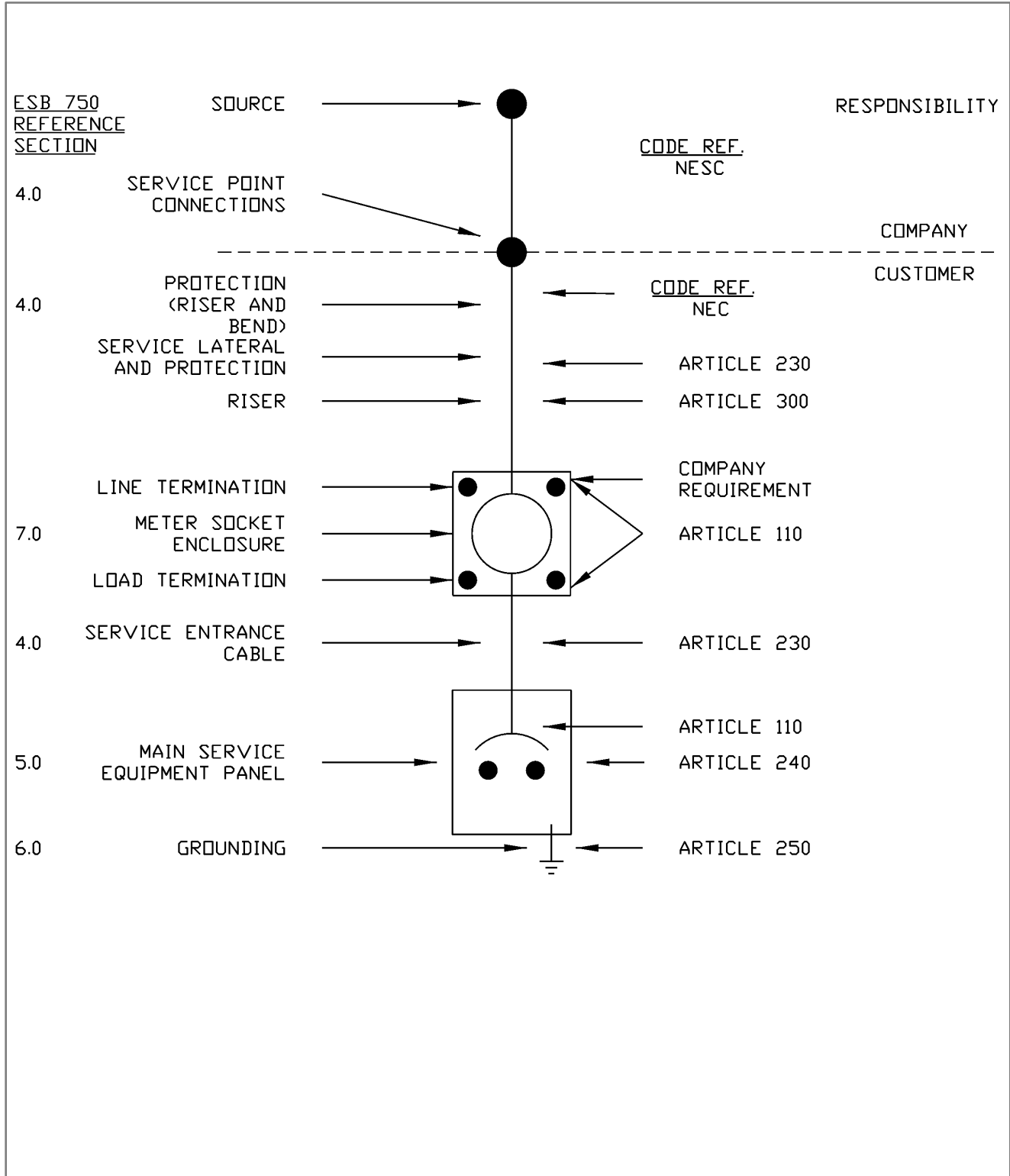

Figure 4.5.1-2: Underground Secondary Service Residential Meter Connection Conduit or Direct Buried

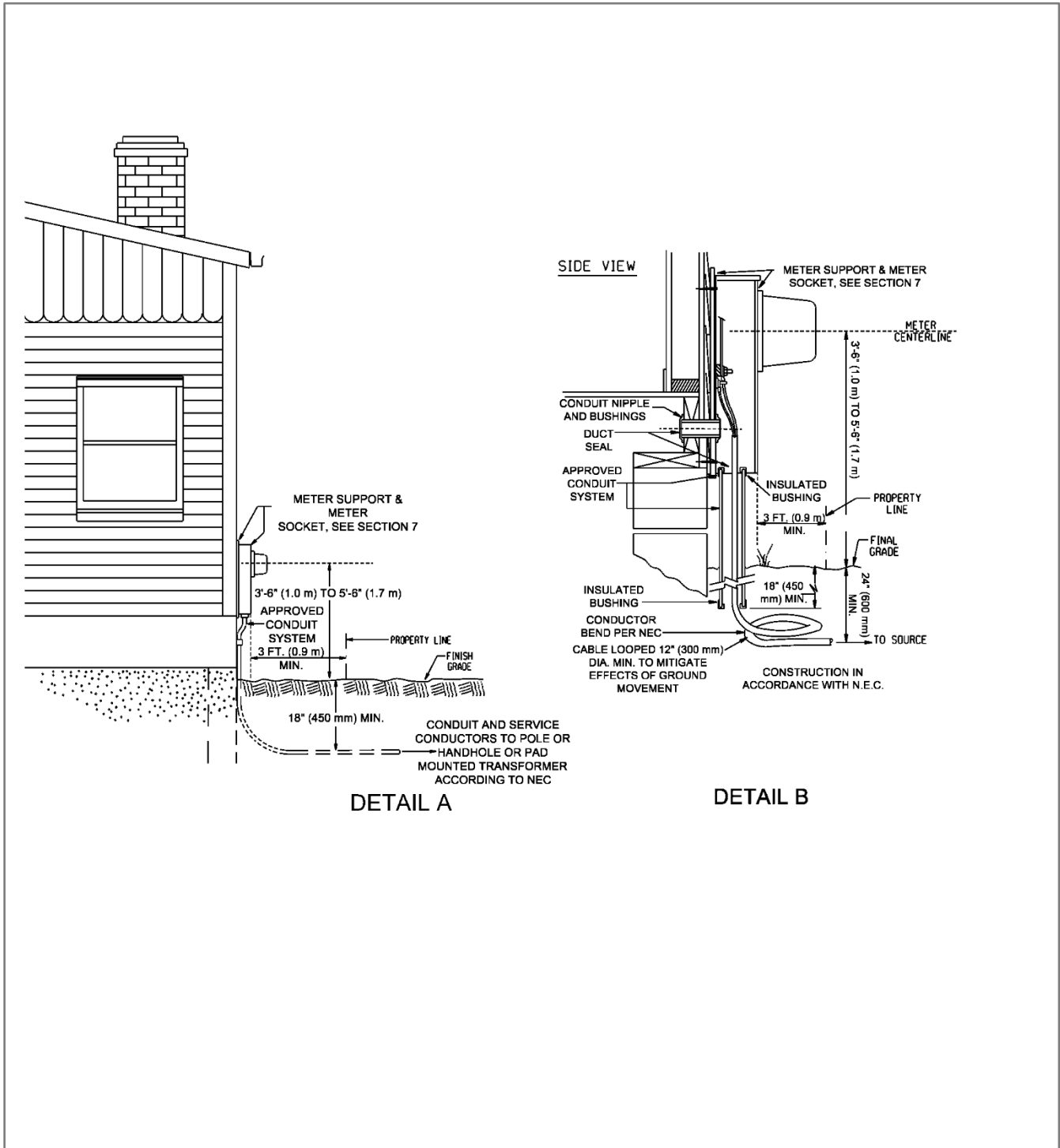
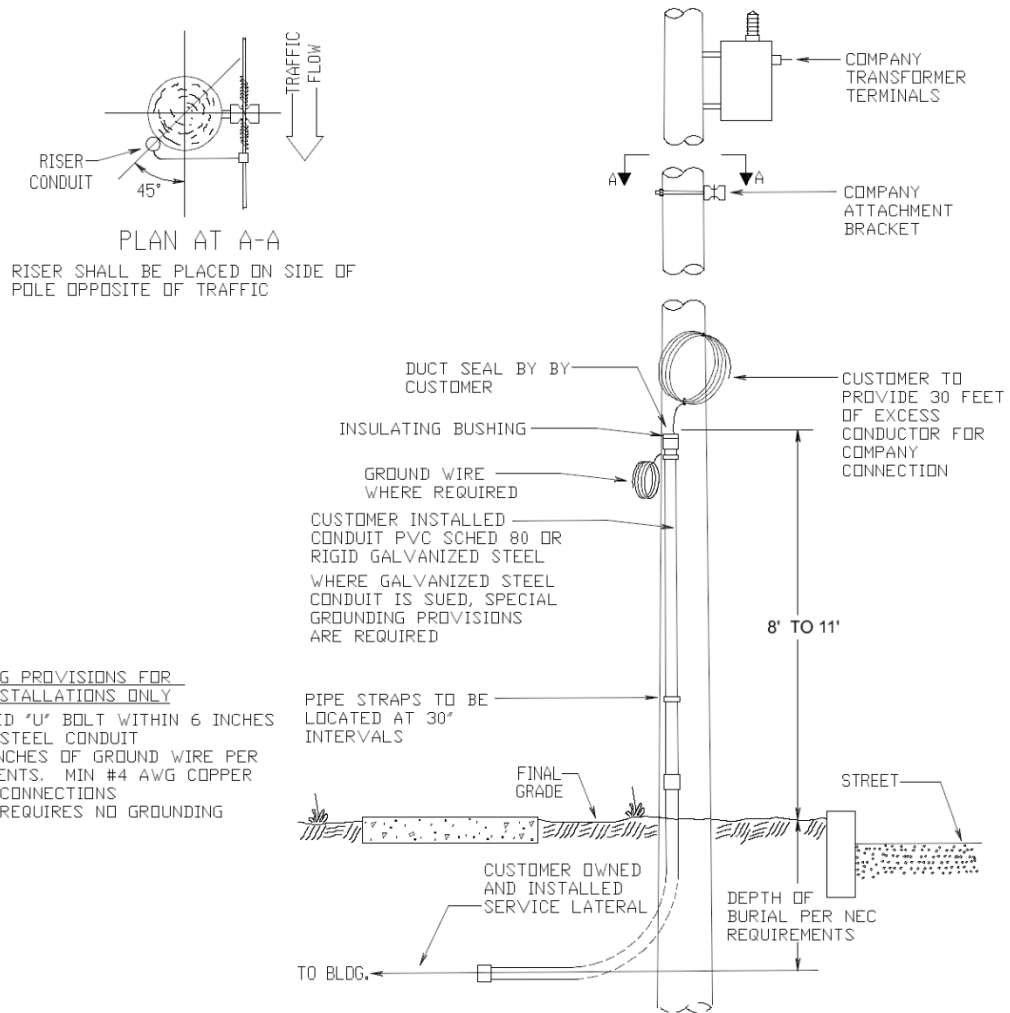

Figure 4.5.4.2-1: Underground Secondary Service Riser Pole



SPECIAL GROUNDING PROVISIONS FOR STEEL CONDUIT INSTALLATIONS ONLY

- INSTALL LISTED 'U' BOLT WITHIN 6 INCHES FROM TOP OF STEEL CONDUIT
- PROVIDE 30 INCHES OF GROUND WIRE PER NEC REQUIREMENTS. MIN #4 AWG COPPER FOR COMPANY CONNECTIONS
- PVC CONDUIT REQUIRES NO GROUNDING PROVISIONS

Figure 4.5.6-1: Underground Residential Distribution Details

Figure 4.5.6-1A

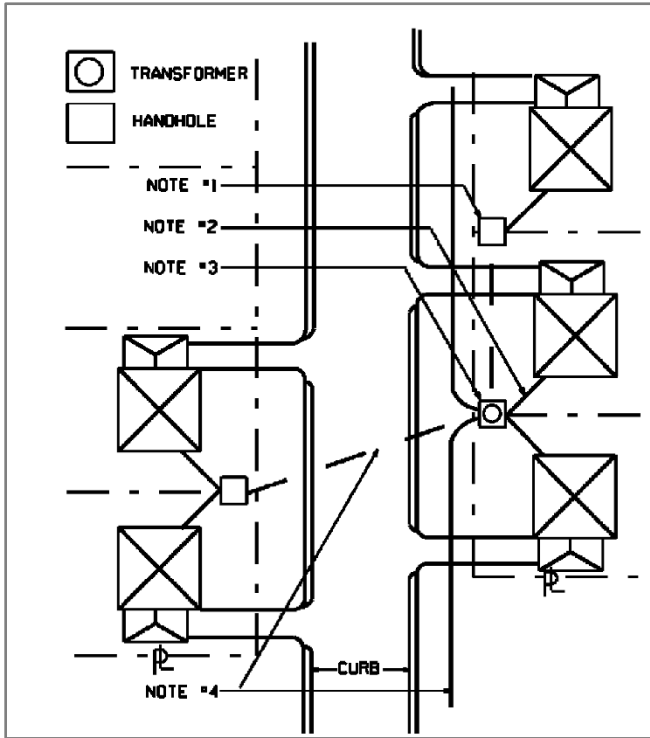

Figure 4.5.6-1B

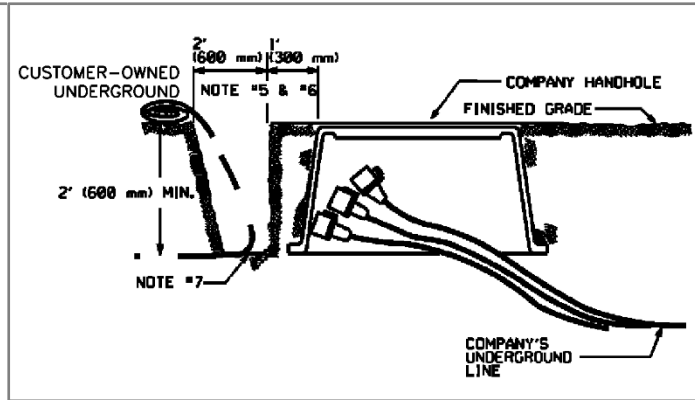
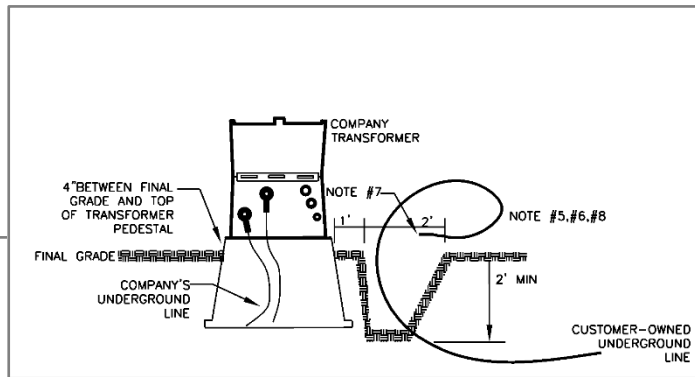

Figure 4.5.6-1C



Notes to Figure 4.5.6-1A:

- (1) Handhole by Company in New York. Handhole is supported by Customer in Massachusetts.
- (2) Customer underground service conductors.
- (3) Single-Phase Transformer by Company.
- (4) Company's underground line.

Notes to Figure 4.5.6-1B/C:

- (5) 200 A service – not more than two sets of service conductors, maximum size 350 KCML.
- (6) 400 A service – not more than two sets of service conductors, maximum size 350 KCML (one set of 500 KCML maximum copper service conductors is acceptable).
- (7) Customer to seal cable ends to prevent entrance of moisture during installation.
- (8) Customer to trench to within 1' of handhole or transformer pad and leave 2' of trench open. Customer to leave adequate length of sealed service conductors for connection by Company. Length for: Handhole – 5'; Transformer – 10'.

Figure 4.5.7.5-1: Typical Service to Multiple Occupancy Building

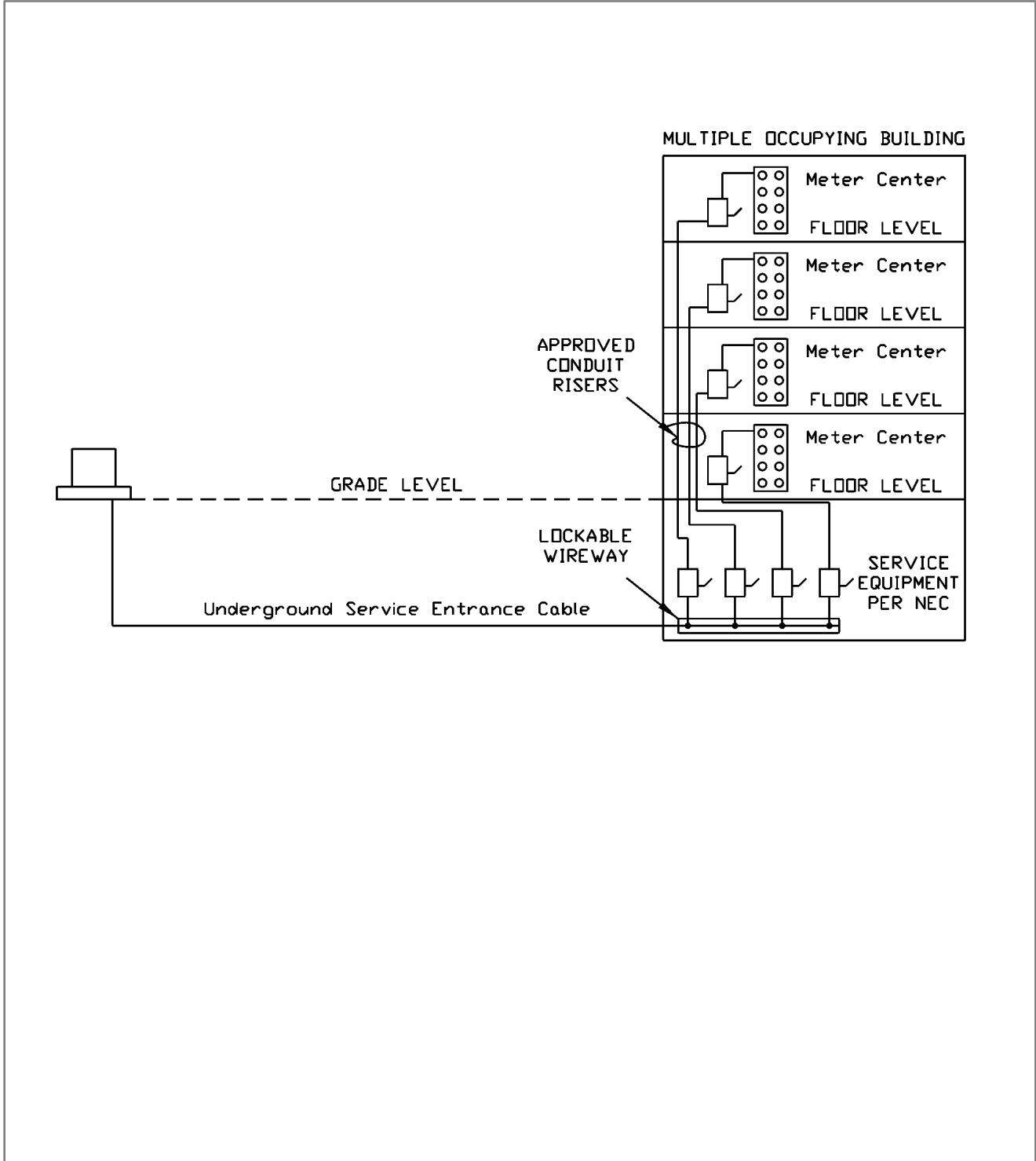
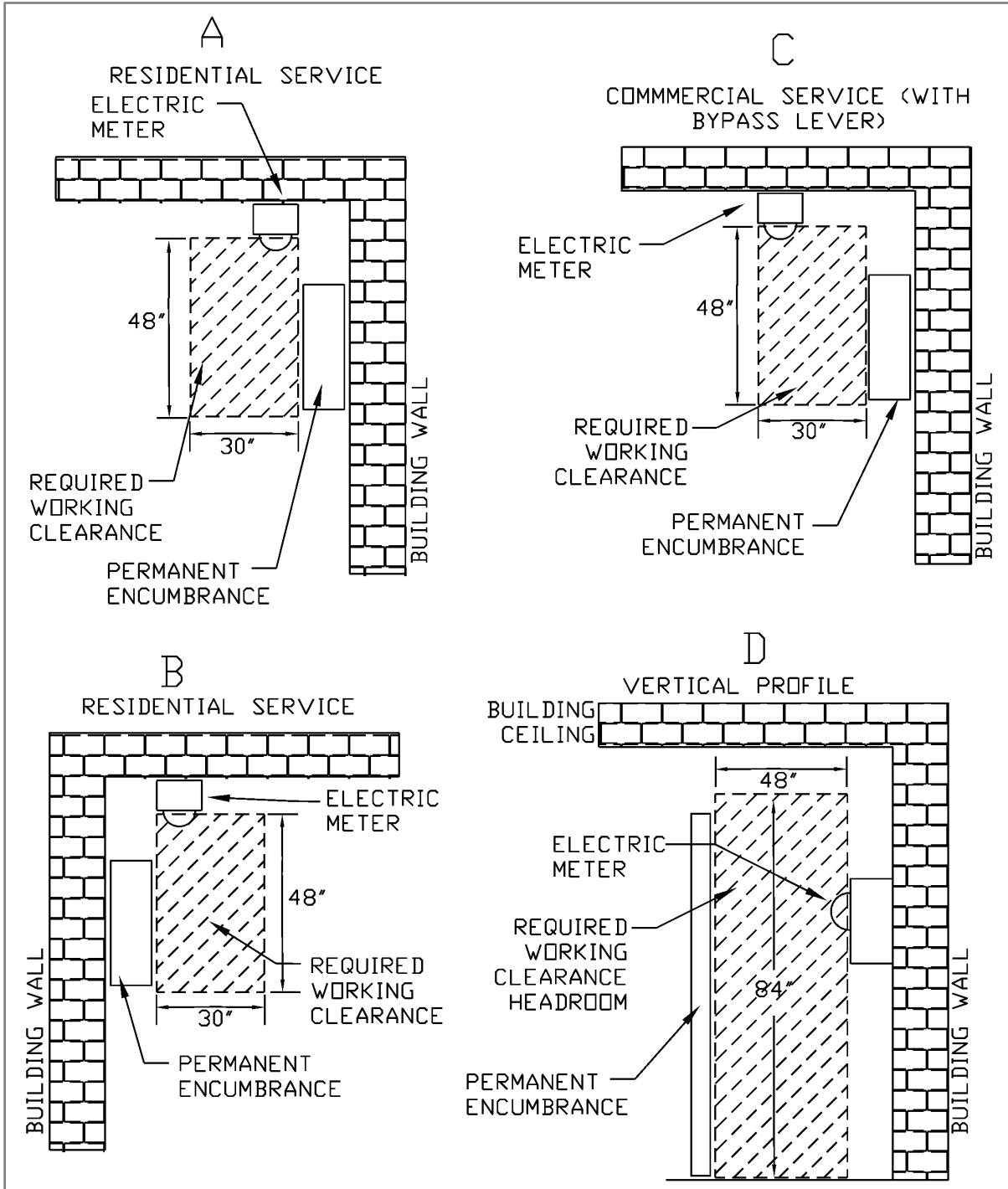

Figure 7.1.2-1: Electric Meter Working Clearances



Notes to Figure 7.1.2-1:

The working space shall be 30" wide. The 30" measurement can be made from either the left or right edge of the meter socket enclosure. Meter socket enclosures with lever bypass handles must have operating space of 30" to the right of the left edge of the meter socket enclosure.

Figure 7.1.2.3-1: Electric Meter to Gas Meter Clearances

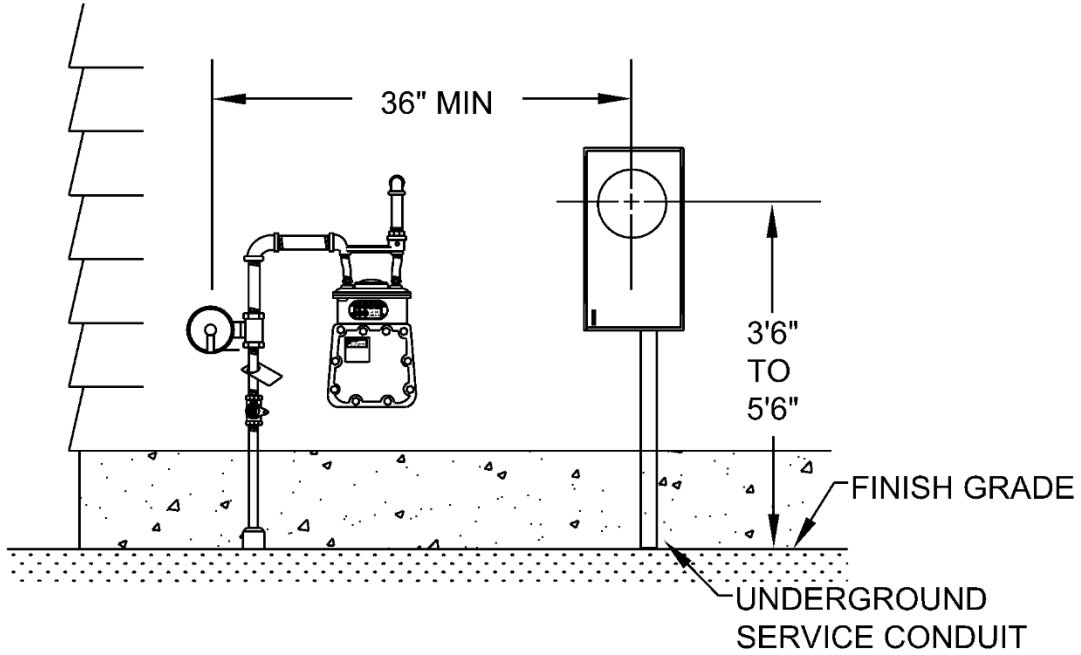
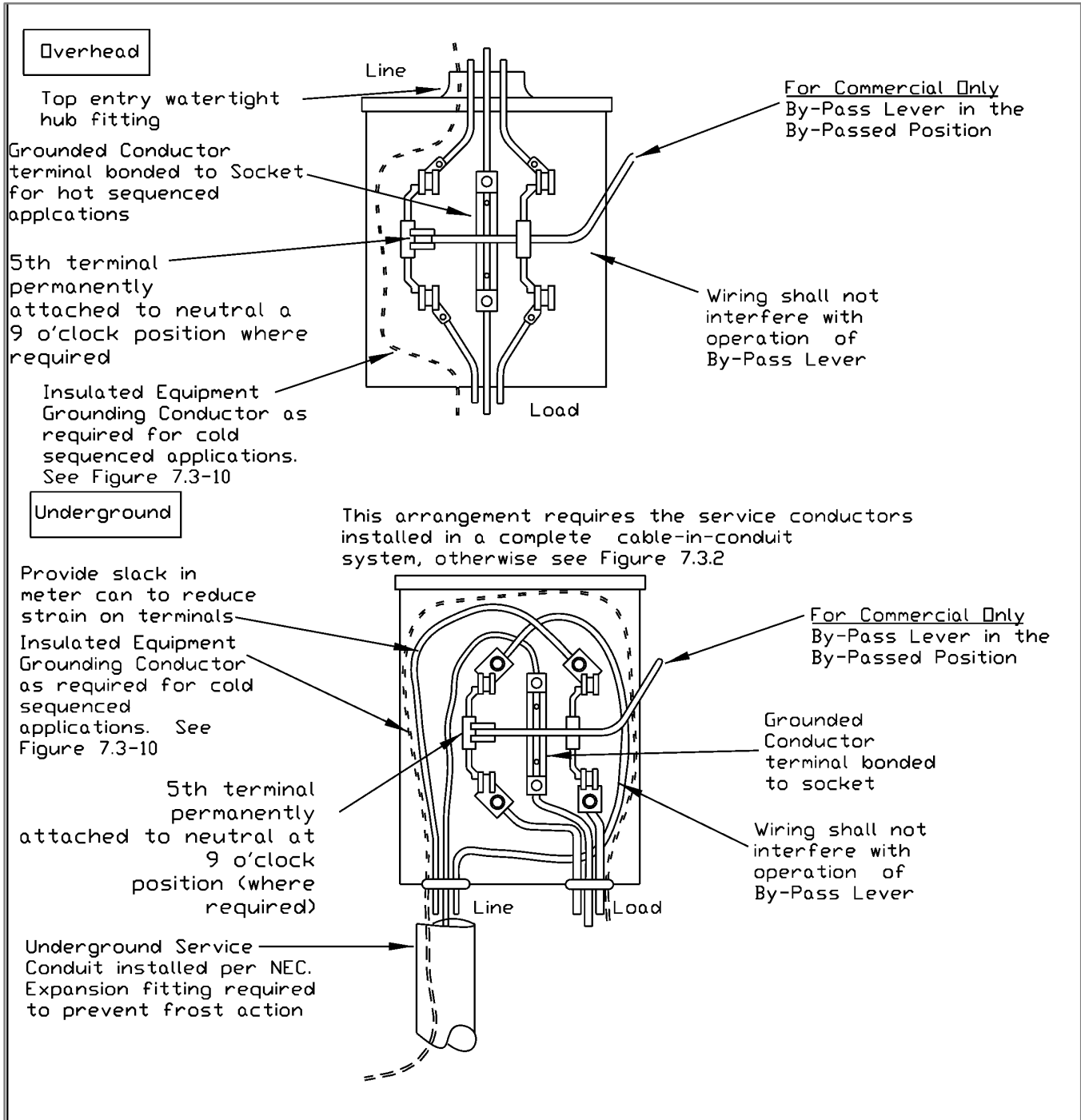
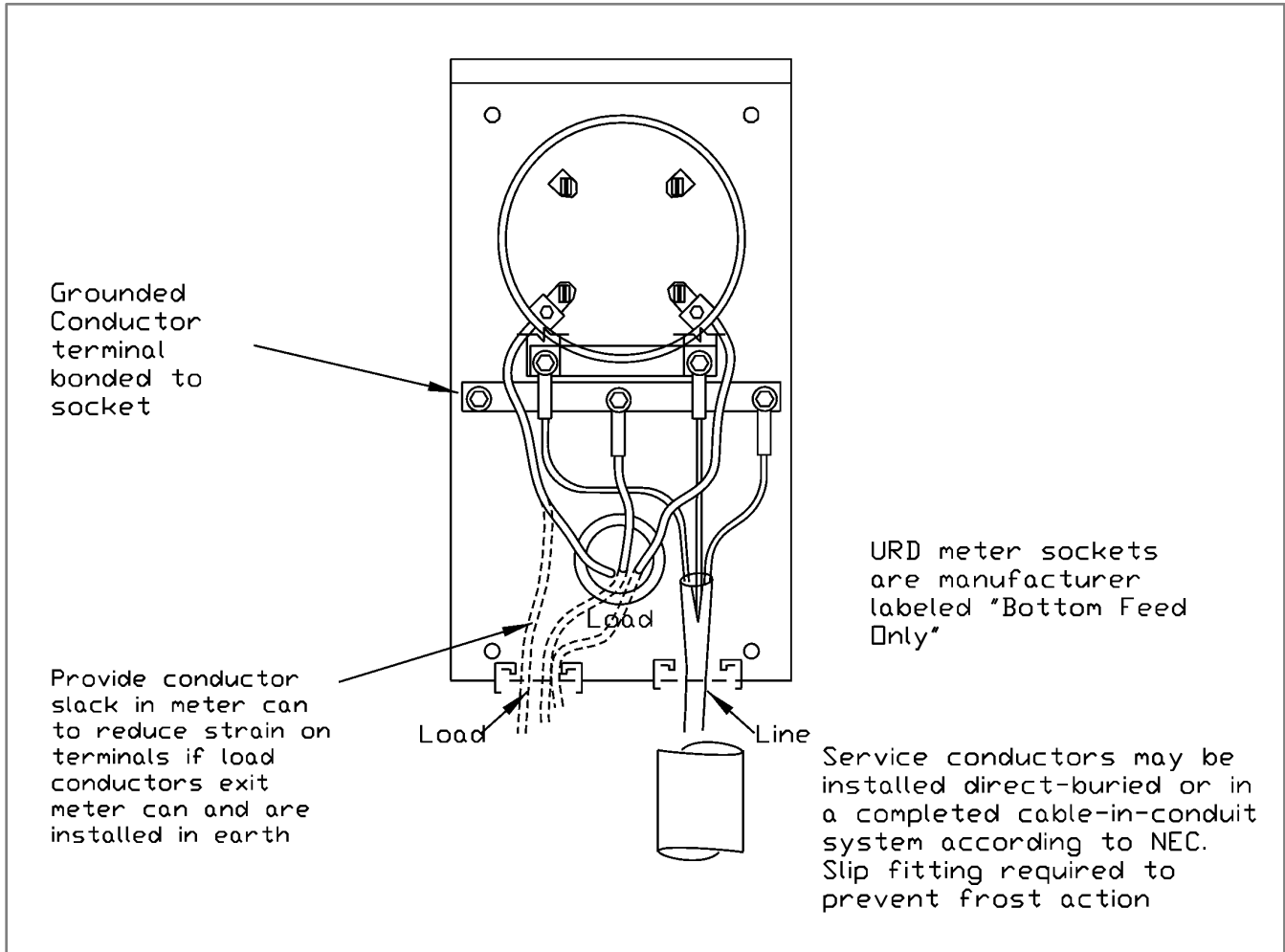

Figure 7.3-1: Residential or Commercial Single-Phase Service 120/240V, 120/208V and 277/480V, 3-Wire, 100 or 200 A; 4 and 5 Terminal Meter Socket; Meter Form – 12S and 2S



Note: See Tables 7.2-1 through 7.2-5, in [Section 7.2](#), for further details on application, requirements, and responsibilities.

Figure 7.3-2: Residential URD (Direct Buried) Single-Phase Service 120/240V, Three-Wire, 100 A or 200 A 4-Terminal Socket Meter Form – 2S



Notes to Figure 7.3-2:

- (A) Underground (bottom entry) types and central wiring space of ganged types shall have 3/8" diameter stud terminals capable of pulling tensions up to 400 lbs. force.
- (9) The Customer shall install crimp type or approved spring-type compression connectors. Mechanical (bolted) connectors are not acceptable.
- (10) Parallel conductors (2 maximum) attached to stud terminals shall be terminated with stackable crimp type compression connectors (or spacers approved and listed for the purpose).
- (11) Completed connection requires two (2) threads of the stud exposed.

See Tables 7.2-1 through 7.2-5, in [Section 7.2](#), for further details on application, requirements, and responsibilities.

Figure 7.3-3: Residential or Commercial Single-Phase Service; 120/240V, 3-Wire, 320 A; 4 Terminal Meter Socket Enclosure Form 2S

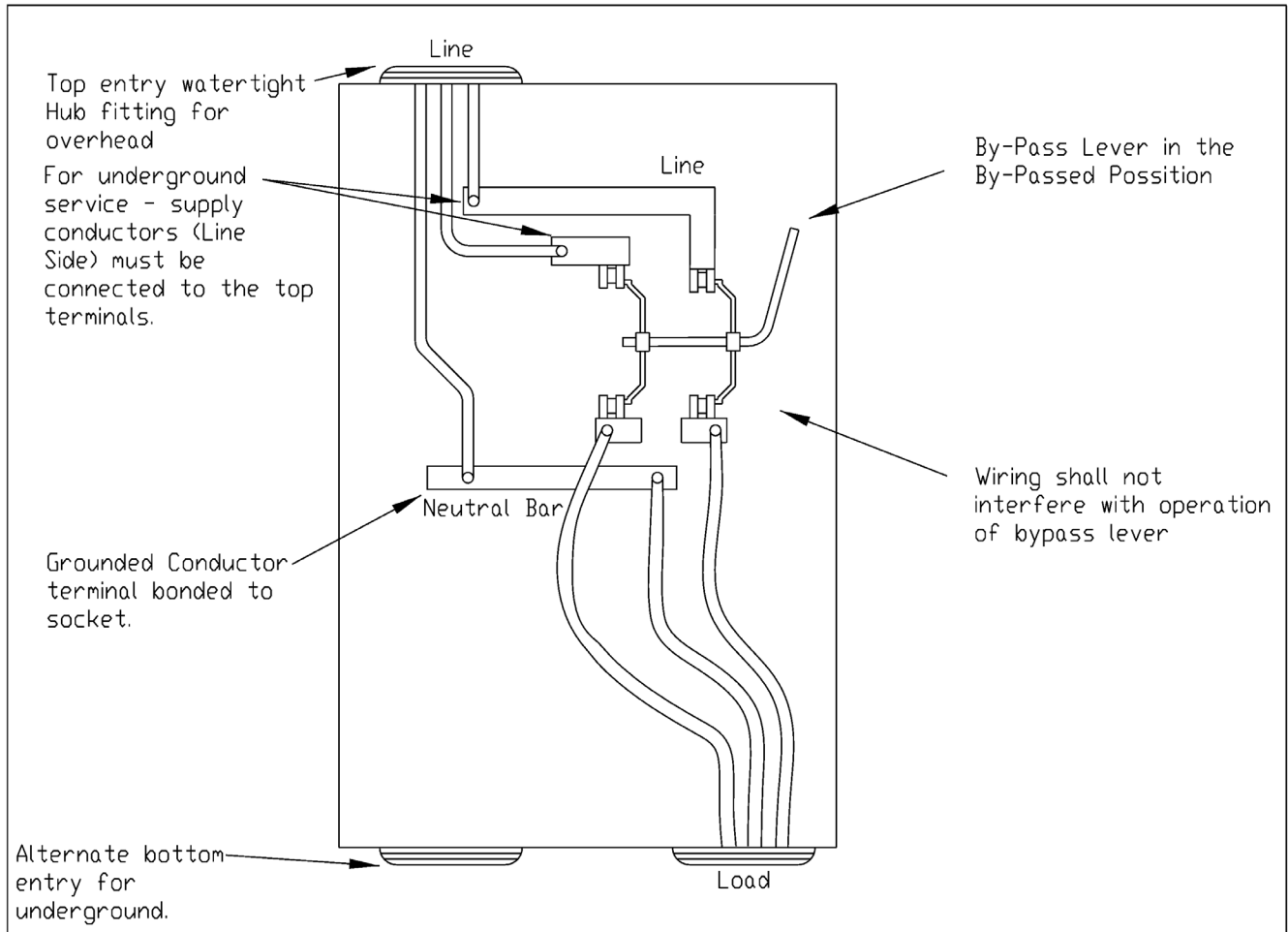

Notes to Figure 7.3-3:

- (A) Service entrance cable or service entrance conductors shall be installed according to the NEC. Side or rear entry not permitted.
- (B) The service entrance conductors for overhead installations shall enter the top of the meter socket and exit the bottom as shown.
- (C) The service entrance conductors for underground installations shall be in the bottom left side of the meter socket and exiting the bottom right.
- (D) Underground service conductors for residential may be installed direct-buried or in a complete cable-in-conduit system according to the NEC. Conduit is required for commercial.

See Tables 7.2-1 through 7.2-6, in [Section 7.2](#), for further details on application, requirements, and responsibilities.

Figure 7.3-4: Commercial Three-Phase Service 208Y/120V and 480Y/277V, 4-Wire, 100 A or 200 A; 7 Terminal Meter Socket Meter Form – 16S

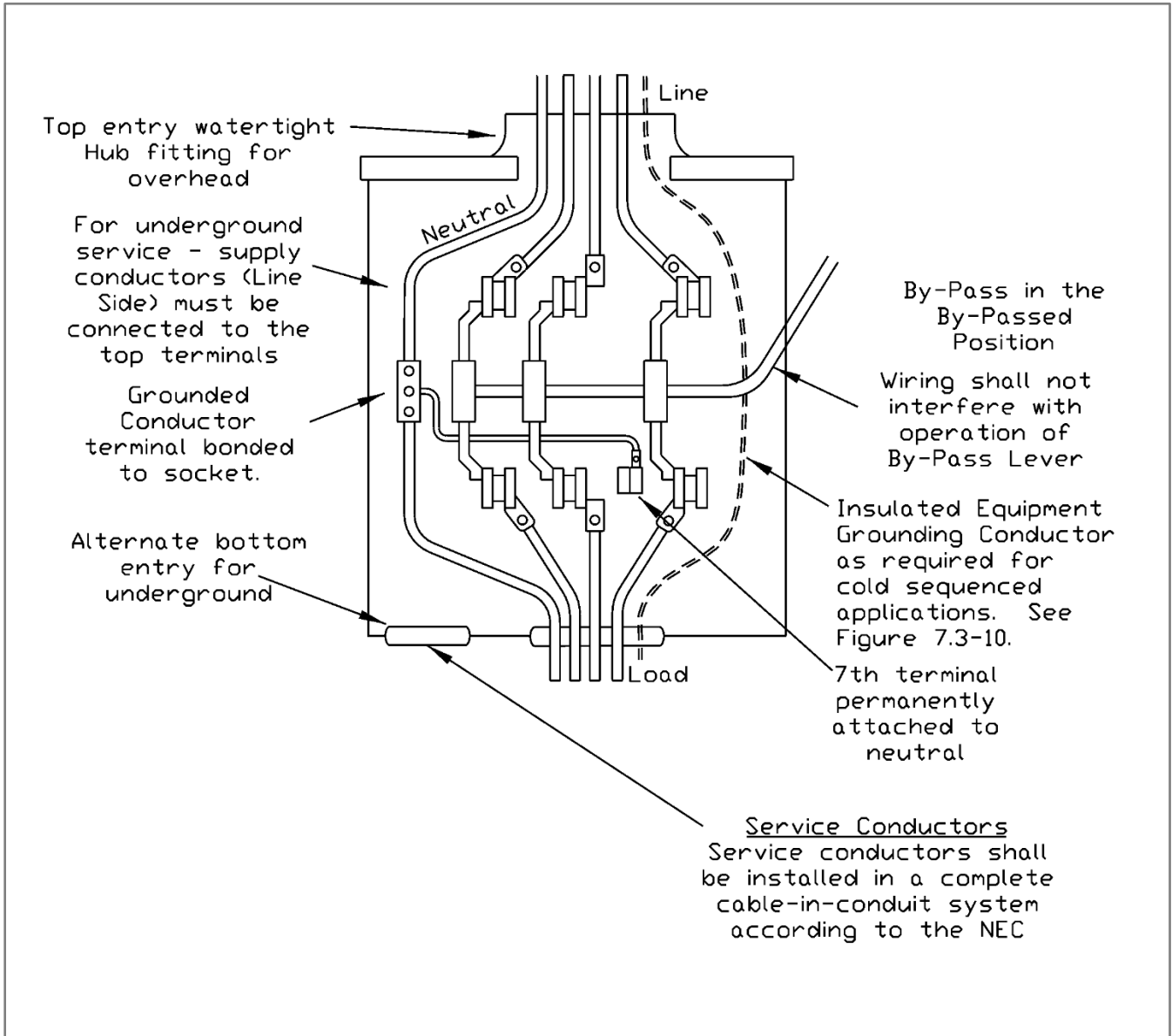

Notes to Figure 7.3-4:

(A) All 480 Volt class self-contained meters shall be cold sequenced. See Figure 7.3-10.

See Tables 7.2-1 through 7.2-5, in [Section 7.2](#), for further details on application, requirements, and responsibilities.

Figure 7.3-5: Commercial Three-Phase Service; 208Y/120V and 480Y/277V, 4-Wire, 320 A; 7 Terminal Meter Socket; Meter Form – 16S

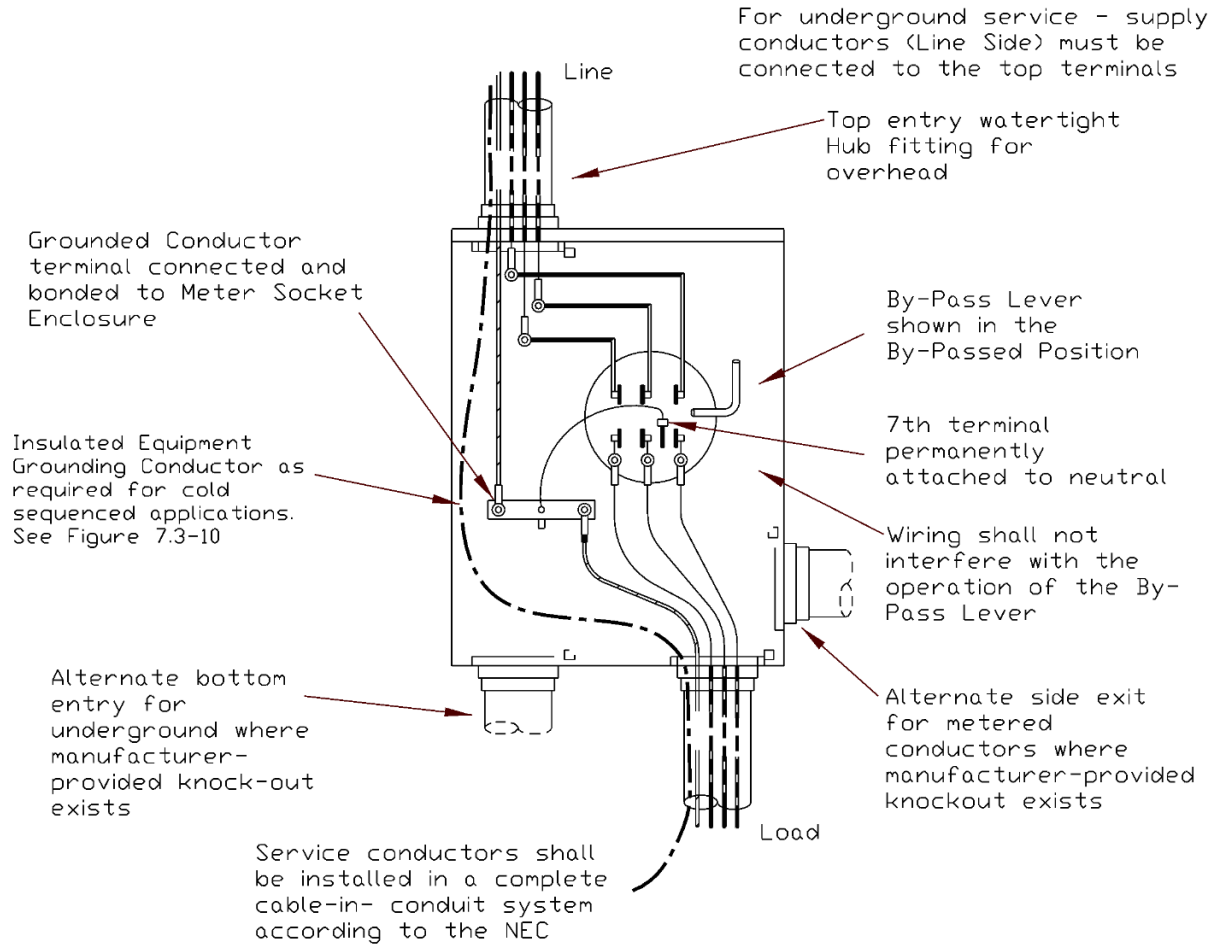

Notes to Figure 7.3-5:

- (A) Applications for three-phase 4-wire 208Y/120V or 480Y/277V 320 A continuous service (one-meter installation).
- (B) Service entrance cable or service entrance conductors shall be installed according to the NEC. Only manufacturer fabricated knockouts shall be utilized for conduit exit.
- (C) The service entrance conductors for overhead and underground installations shall follow the details outlined in Figure 7.3-5.
- (D) Cold sequence metering arrangement is required if three-phase 480Y/277V service. See [Figure 7.3-10](#).

See Tables 7.2-1 through 7.2-6, in [Section 7.2](#), for further details on application, requirements, and responsibilities.

Figure 7.3-6: Residential or Commercial 2-to-6 Ganged Single-Phase Service; 120/240V 3-Wire; 4 Terminal Meter Socket; Meter Form – 2S

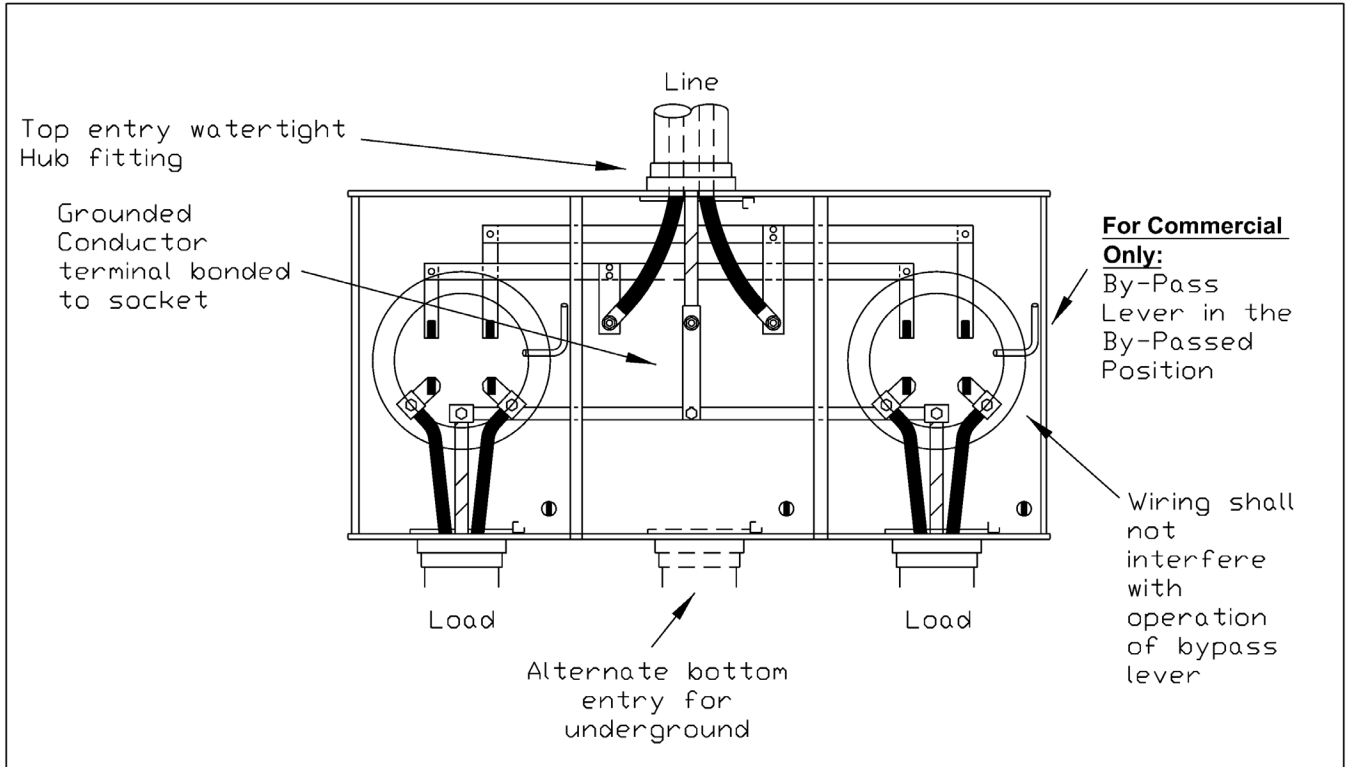

Notes to Figure 7.3-6:

- (A) One-hole pad crimp-type or spring-type compression connector for 3/8" stud sized to be to be furnished and installed by Customer.
- (B) Ganged meter channels cannot be modified for additional positions.
- (C) Connect grounded circuit to service equipment neutral bus.
- (D) Grounding system shall be installed according to NEC requirements.
- (E) Load side to Customer service equipment. If the meters serve another building or structure, service equipment shall be adjacent to the meters.
- (F) For underground service, service conductors for residential may be installed direct-buried or in a complete cable-in conduit system according to NEC. Conduit is required for commercial.
- (G) For 120/208V Form 12S, refer to [Figure 7.3-1](#) for 5th terminal location.

See Tables 7.2-1 through 7.2-5, in [Section 7.2](#), for further details on application, requirements, and responsibilities.

Figure 7.3-7: Service Pedestal Single-Phase Service; 120/240V 200 A and 120/208V 100 A, 3-Wire; 4 and 5 Terminal Meter Socket; Meter Form – 2S and 12S

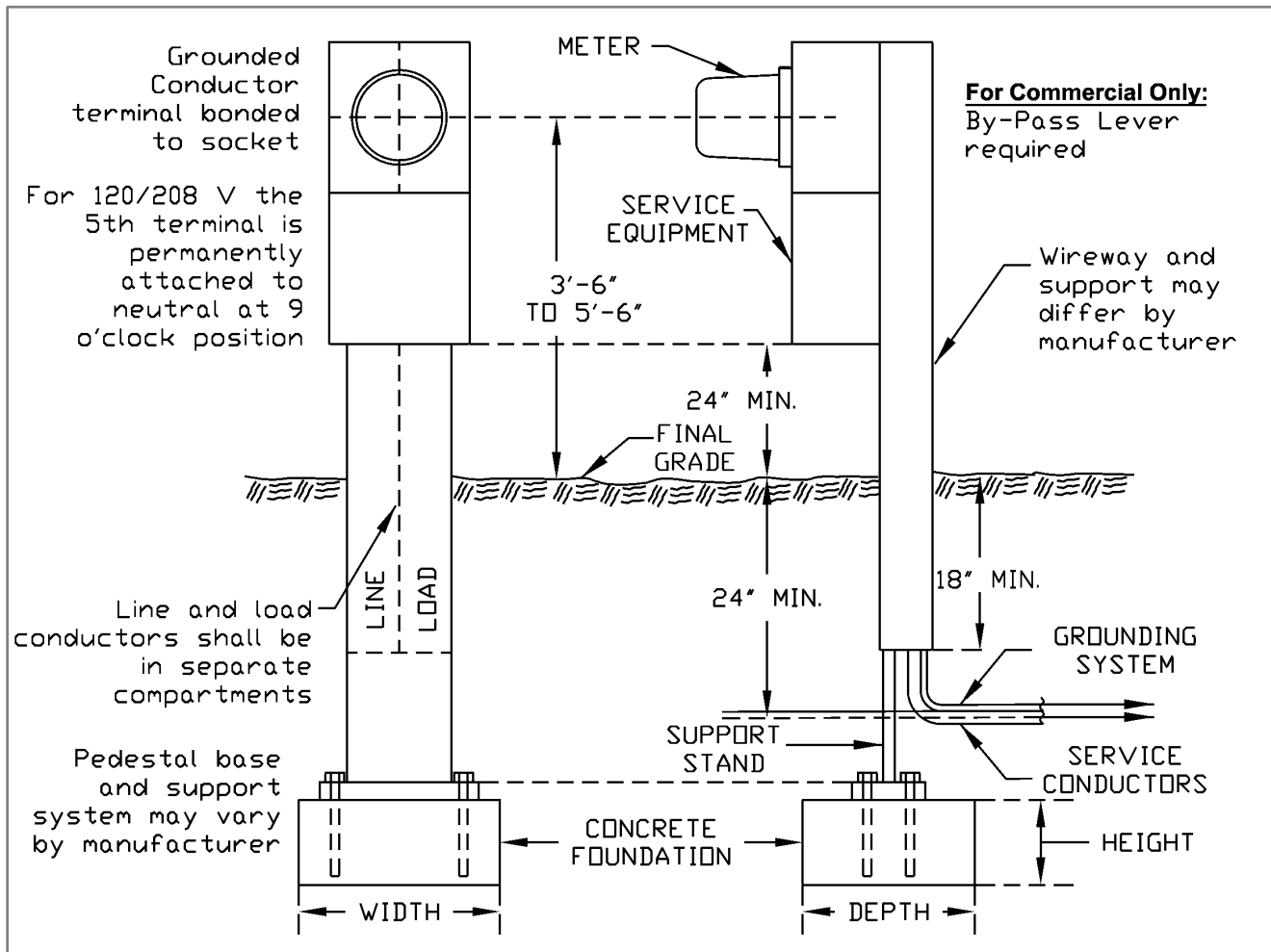

Notes to Figure 7.3-7:

- (A) Grounding system installed as required by NEC.
- (B) Underground service conductors to handhole or transformer by Customer for residential services may be installed direct-buried or in a complete cable-in-conduit system according to NEC. Conduit is required for commercial service installations. ***Metered and unmetered conductors shall not occupy same raceway.** Six (6) inch minimum cable separation required between line and load cables in common trench.
- (C) Concrete footing minimum dimensions shown for a single pedestal (28" wide, 18" deep, 12" high) greater size footing required for multiple or larger pedestal units.
- (D) Service pedestal to be furnished, installed and maintained by Customer. Pedestal shall meet [Table 7.2-2](#) for meter socket section. Pedestal location shall be accepted by the Company.
- (E) Other service supports may be considered. Prior to approval is required from the Company.
- (F) Consult the Company for three-phase, 320 A meters and 480V applications.
- (G) See Tables 7.2-1 through 7.2-5, in [Section 7.2](#), for further details on application, requirements, and responsibilities.

See [Section 4.5.7.1](#) for more information.

Figure 7.3-8: Residential or Commercial Meter Center (More Than 6 Meters); 4 and 5 Terminal Meter Socket; Meter Form – 2S and 12S and 16S

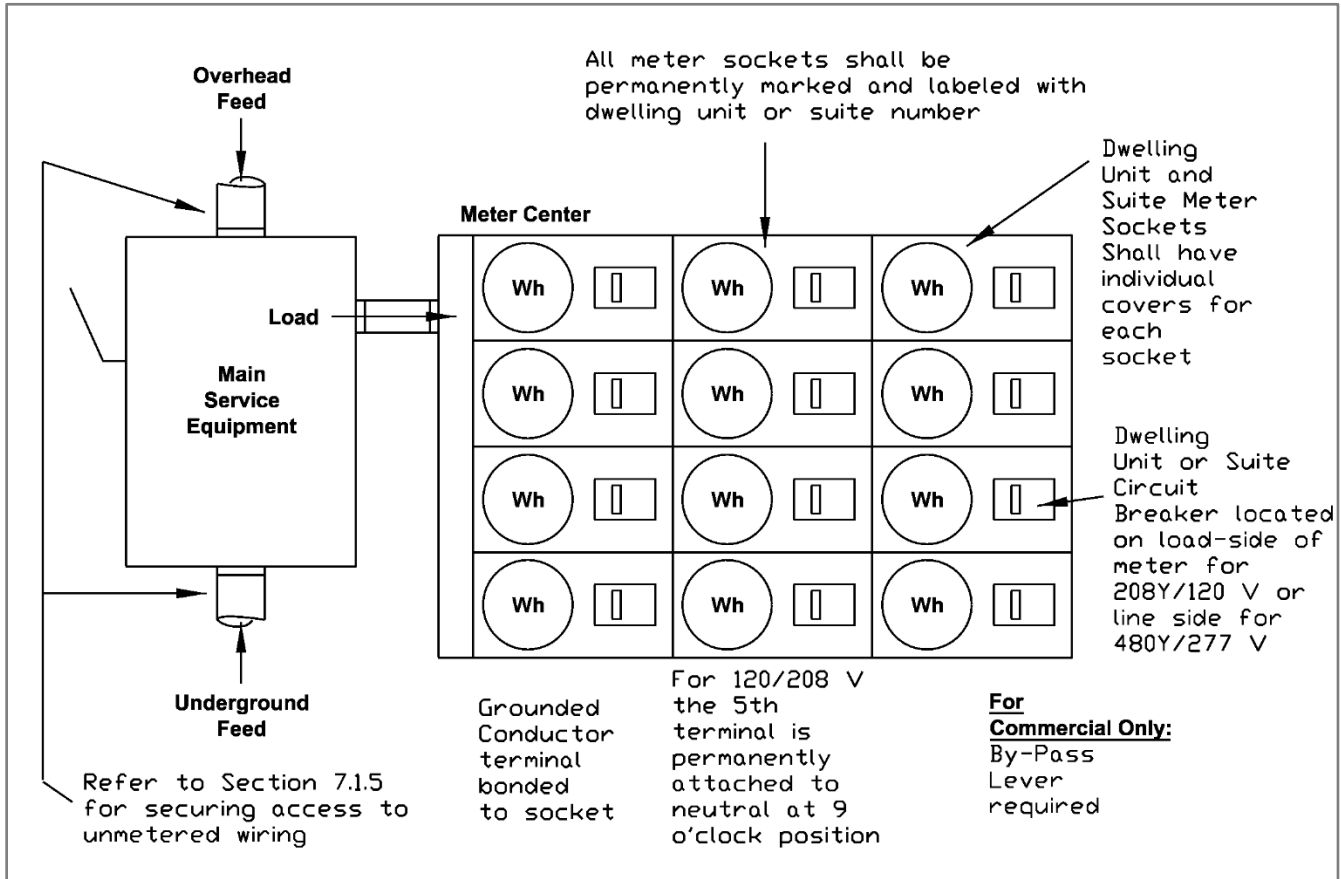

Notes to Figure 7.3-8:

- (A) Bond metallic conduit in accordance with NEC Article 250.
- (B) See [Section 4.0](#) for service entrance conductors in approved conduit and sized according to NEC.
- (C) Meter board/support construction according to [Section 7.7](#) and securely mounted, at least 6" from top of meter board to ceiling or beam.
- (D) For 120/208V, the 5th terminal is permanently attached to neutral at 9 o'clock position.
- (E) 6'-0" maximum above floor or final grade to center of top row of meters.
- (F) 2'-0" minimum above floor indoors and 2'-6" minimum above final grade outdoors to center of bottom row of meters.
- (G) Refer to [Table 7.2-2](#), item #14 regarding meter socket enclosure cover plates. Minimum of 4' clearance shall be maintained in front of meter socket enclosure.

See Tables 7.2-1 through 7.2-6, in [Section 7.2](#), for further details on application, requirements, and responsibilities.

Figure 7.3-9: Residential Ganged for Up To 4 Mobile Homes Single-Phase Service; 120/240V 3-Wire; 4 Terminal Meter Socket; Meter Form 2S

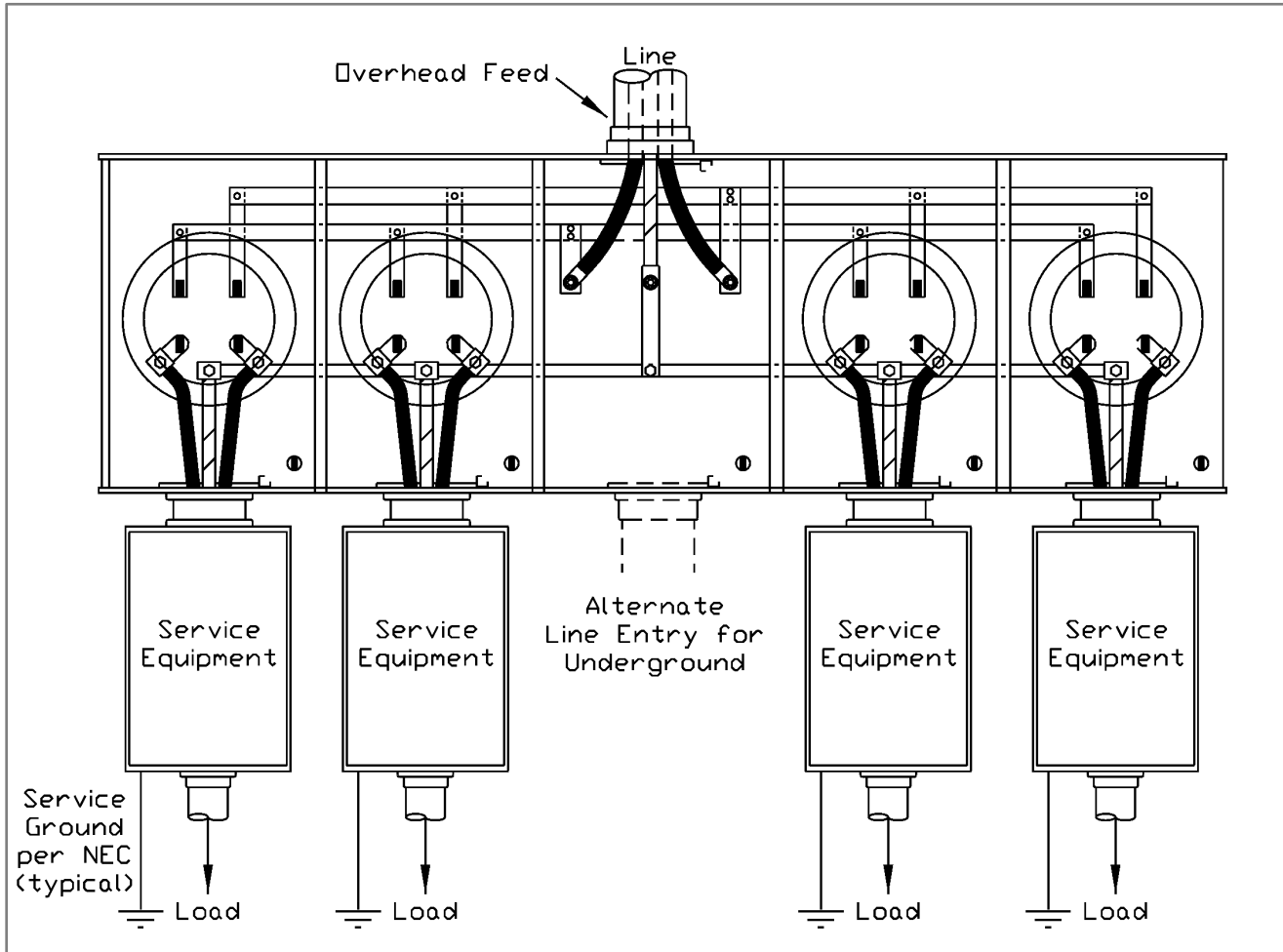

Notes to Figure 7.3-9:

- (A) Service arrangement to be used for existing overhead served mobile home parks or new groups of up to four mobile homes where URD rules do not apply and where single meter or grouped indoor meter installation is not practical.
- (B) See [Section 4.0](#) for service entrance conductors in approved conduit and sized according to NEC. If metallic conduit, bond conduit in accordance with NEC.
- (C) Install service entrance ground in accordance with NEC.
- (D) Outdoor meter support materials and construction according to [Section 7.7](#) and securely mounted.
- (E) Meter sockets are supplied by the Customer and the Company will supply the meters. All meter sockets shall be permanently and labeled with individual mobile homes served.
- (F) Disconnect may be located as shown, or integral to the meter socket enclosure. Replacement in kind for existing Recreational Vehicle (RV) Parks shall be permitted.
- (G) For 120/208V Form 12S, refer to [Figure 7.3-1](#) for 5th terminal location.

See Tables 7.2-1 through 7.2-6, in [Section 7.2](#), for further details on application, requirements, and responsibilities.

Figure 7.3-10: Typical Three-Phase and Single-Phase Cold Sequenced Metering Arrangement

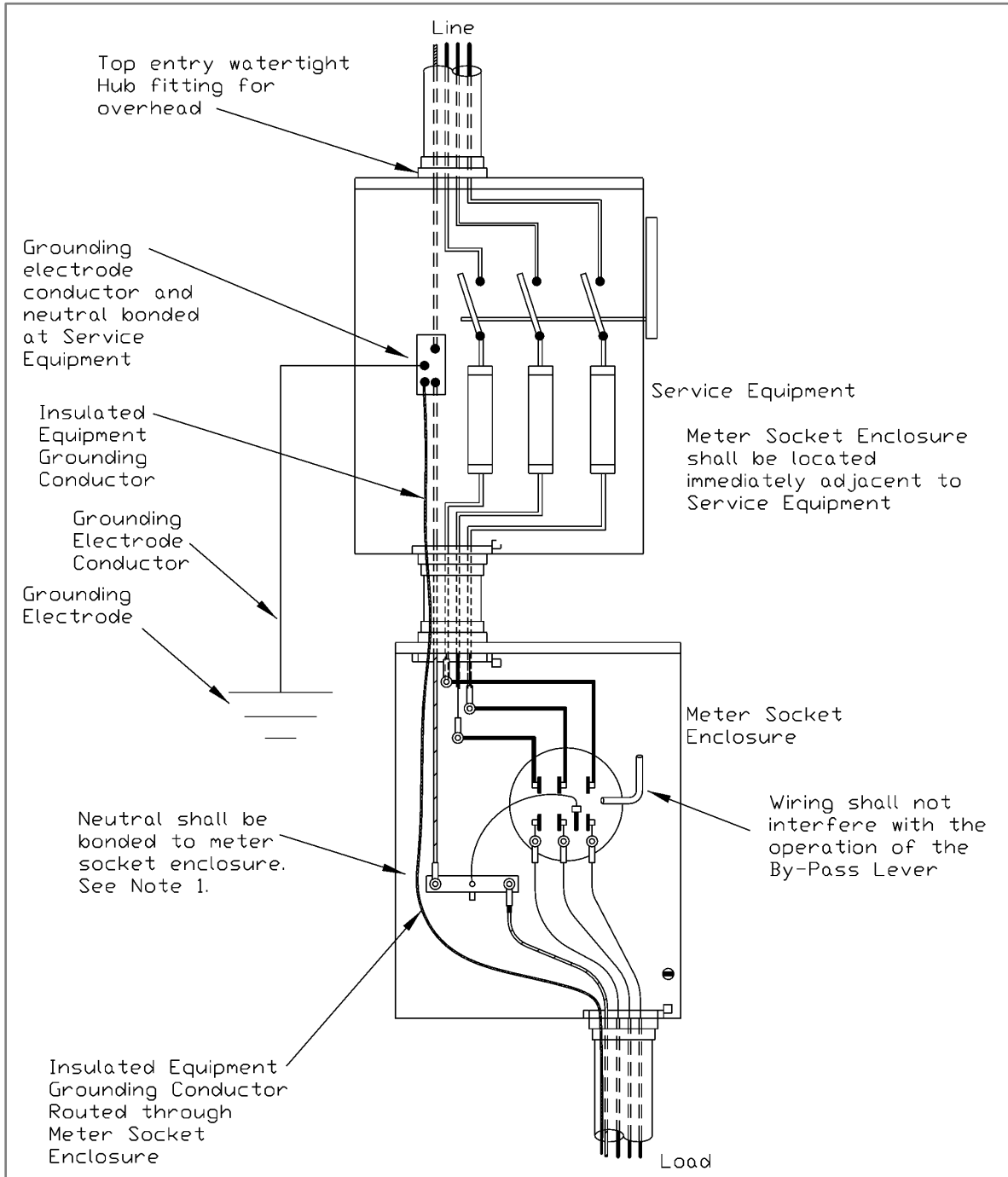

Note to Figure 7.3-10:

Where NEC requires a separate equipment grounding conductor in a cold sequenced arrangement, this terminal may be insulated from the meter socket enclosure. Suitably marked and insulated equipment grounding conductor may be allowed to pass through and bond meter socket enclosure for such arrangements.

Figure 7.4.1-1a: Transformer Rated Metering Cabinet; Secondary Metering Installation; 120/240V, Single-Phase (Maximum 400 A); 208Y/120V and 480Y/277V Three-Phase (400 A through 800 A)

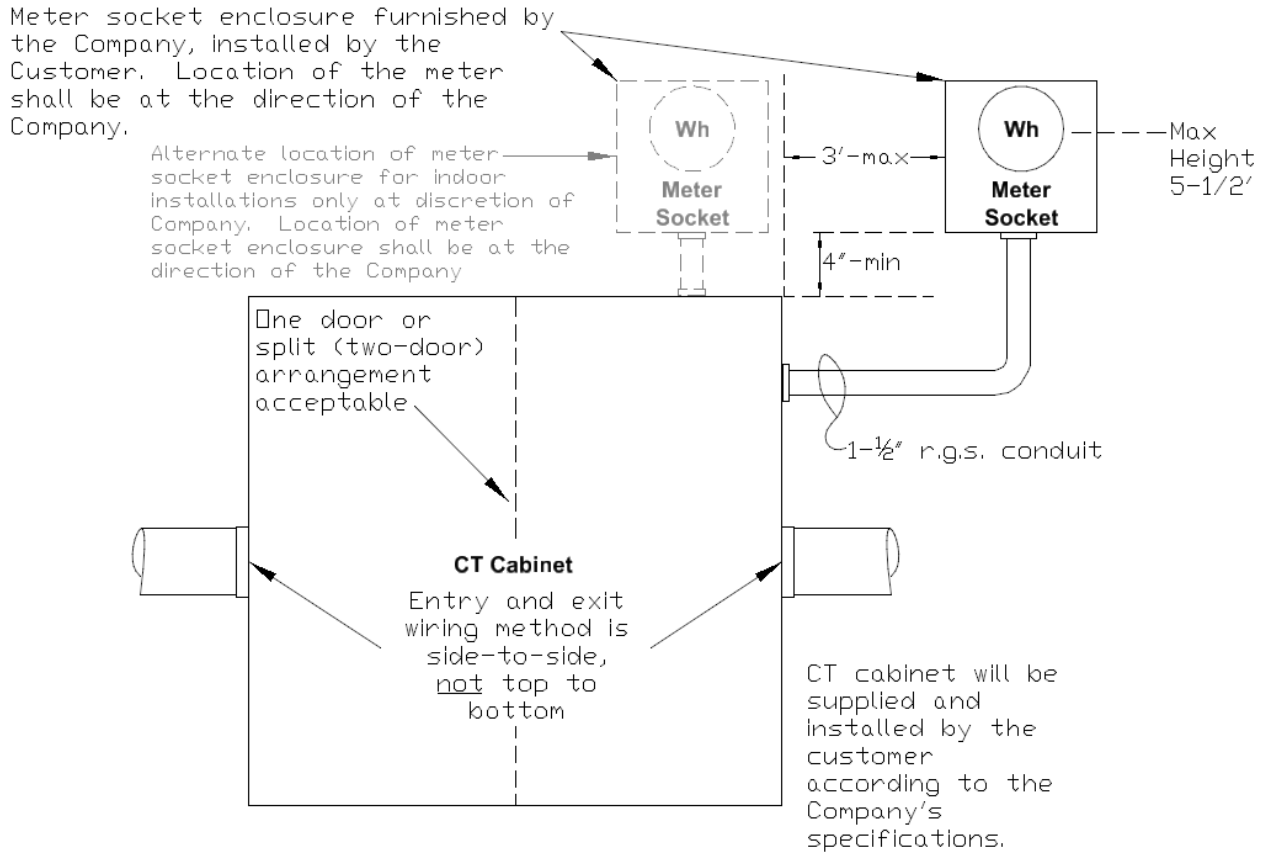

Notes to Figure 7.4.1-1a:

Customer-owned Metering CT Cabinet Requirements:

- (A) Minimum Size – 36" width x 36" height x 10" deep.
- (B) Rolled Lip Cover.
- (C) Permanently installed hinge pins, removable cover in open position.
- (D) Padlock and Sealing Provisions. Door shall be secured by a minimum of two (2) bolts at side of opening or three-point handle assembly.
- (E) NEMA 3R Rainproof Enclosure Indoor/Outdoor Use.
- (F) Listed by Independent Recognized Testing Laboratory.
- (G) Mounting Provisions shall be provided by manufacturer and shall consist of a full cabinet height and width metallic mount backplane for mounting Company-supplied instrument transformers. Plywood is not acceptable for mounting Company-provided instrument transformers.
- (H) Acceptable entry and exit wiring on sides; not top and bottom.
- (I) Grounding Stud for connection to equipment grounding or bonding conductor, per NEC requirements.
- (J) The Customer shall consult with the Company prior to CT metering cabinet installation.
- (K) Conduit bodies are prohibited on the incoming (unmetered) wireway.

See [Table 7.2-1](#) and [Section 7.4](#) for further details on application, requirements, and responsibilities.

Figure 7.4.1-1b: Transformer Rated Metering Cabinet Bonding

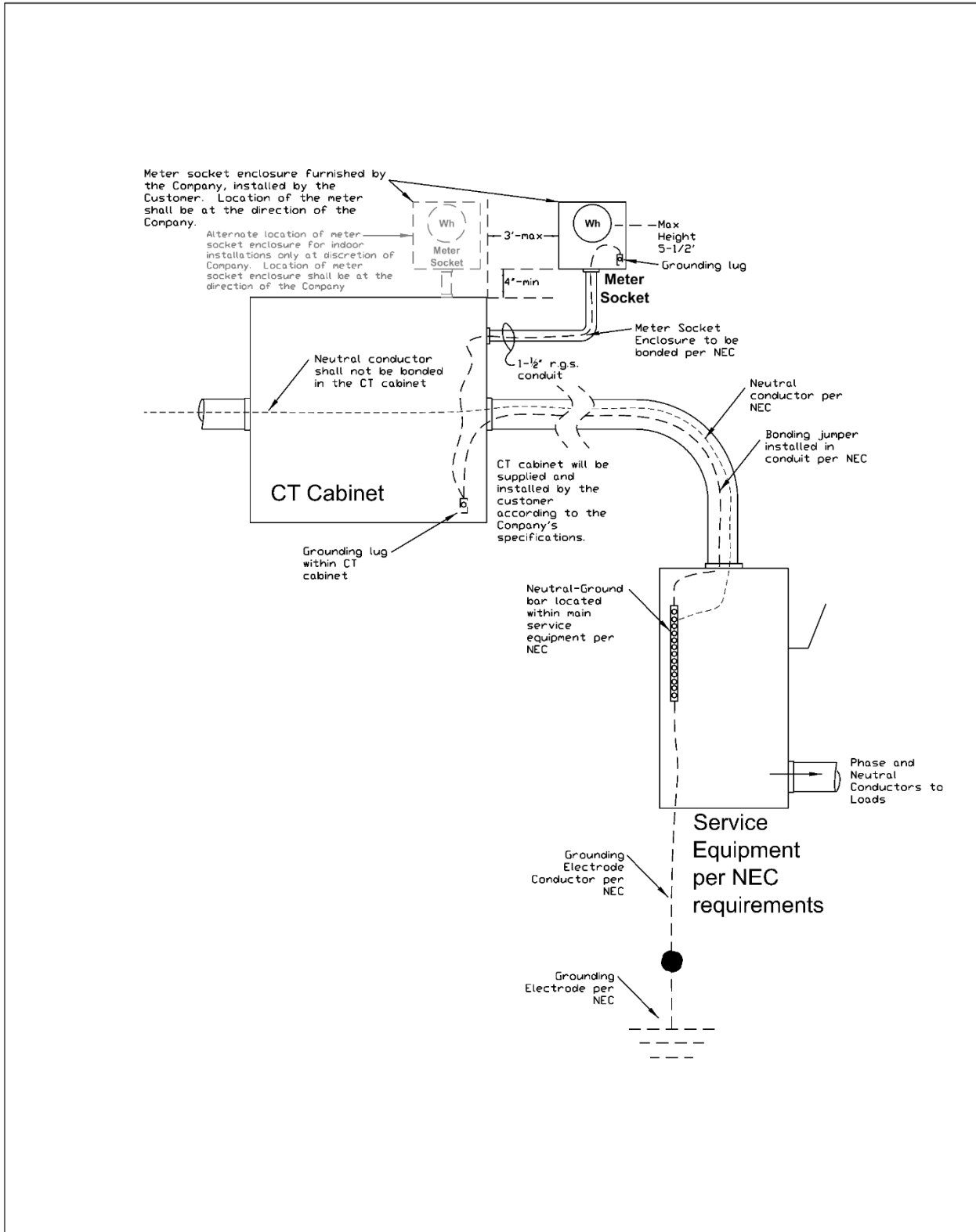
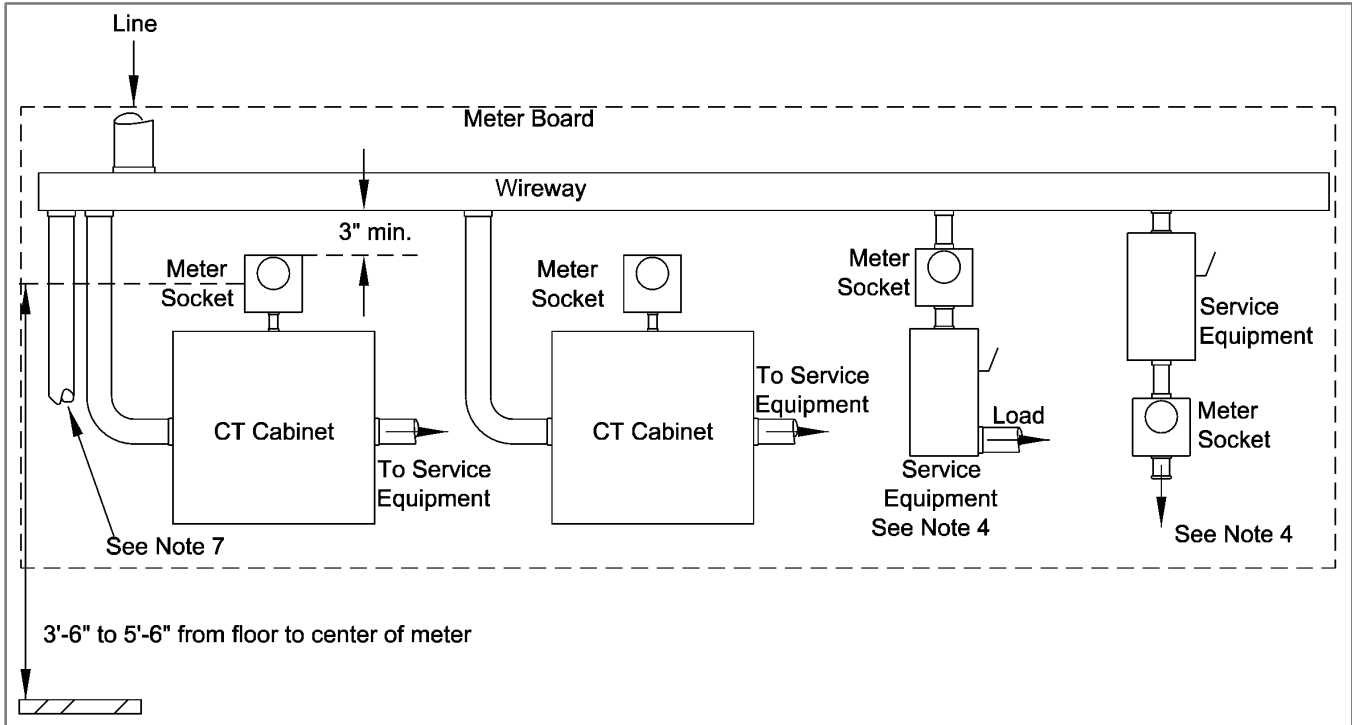

Figure 7.4.1-2: Typical Commercial Installation 2 to 6 Meters



Notes to Figure 7.4.1-2:

- (A) See [Section 7.4.1](#), [Figure 7.4.1-1a](#), and [Figure 7.4.1-1b](#) for metering CT cabinet requirements, 400 A to 800 A.
- (B) 1-1/2" rigid galvanized steel conduit required between CT cabinet and meter socket.
- (C) See [Section 7.2](#) and [Section 7.3](#) for appropriate self-contained meter socket installation below 400 A.
- (D) (Figure Note 4) Cold sequence installation required for 480V class self-contained meter sockets. Hot sequence installations required for 208 and 240V class self-contained meter sockets.
- (E) Wireway shall be in accordance with NEC requirements and shall include hasps for locking or sealing by the Company.
- (F) See [Section 7.7](#) for Meter Board requirements.
- (G) (Figure Note 7) For underground service installations, the wireway may be located below the service equipment and metering equipment.
- (H) Taps and/or splices within wireways/auxiliary gutters, ahead of main service equipment, shall be made as per the NEC. Bite connectors are prohibited.

See Tables 7.2-1 through 7.2-6, in [Section 7.2](#), for further details on application, requirements, and responsibilities.

Figure 7.4.1-3: Typical Outdoor Transformer Rated Meter Installation from Customer Service Pole

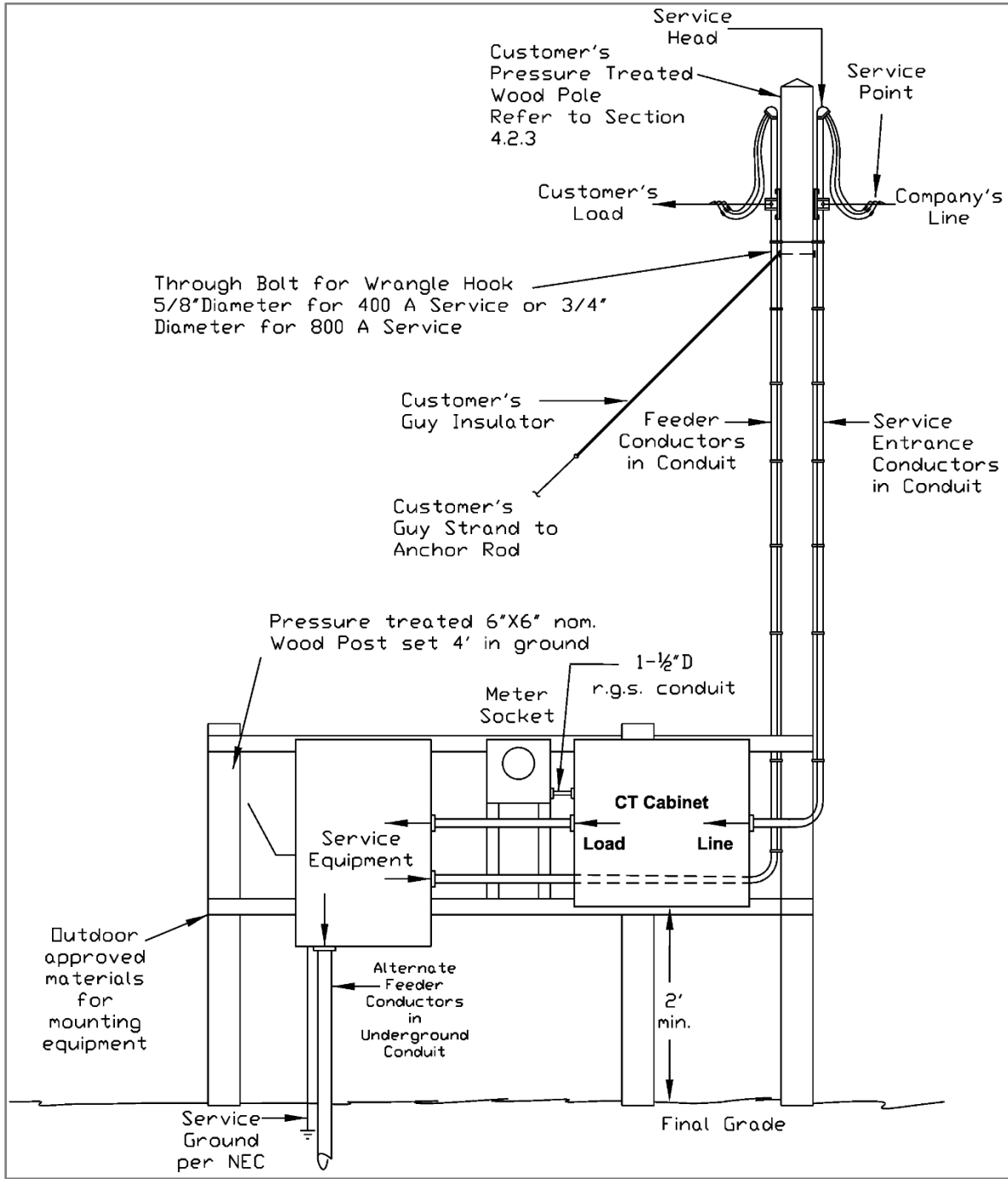

Notes to Figure 7.4.1-3:

- (A) See [Section 7.4.1](#), [Figure 7.4.1-1a](#), and [Figure 7.4.1-1b](#), for metering CT cabinet requirements, 400 A to 800 A.
- (B) See [Section 7.7](#) for Meter Support requirements.

See [Table 7.2-1](#) for further details on application, requirements, and responsibilities. See [Section 4.0](#) for overhead service connection requirements.

Figure 7.4.6.2-1: Instrument Transformer Metering Sequence; Service Cubicles – 600V Rating

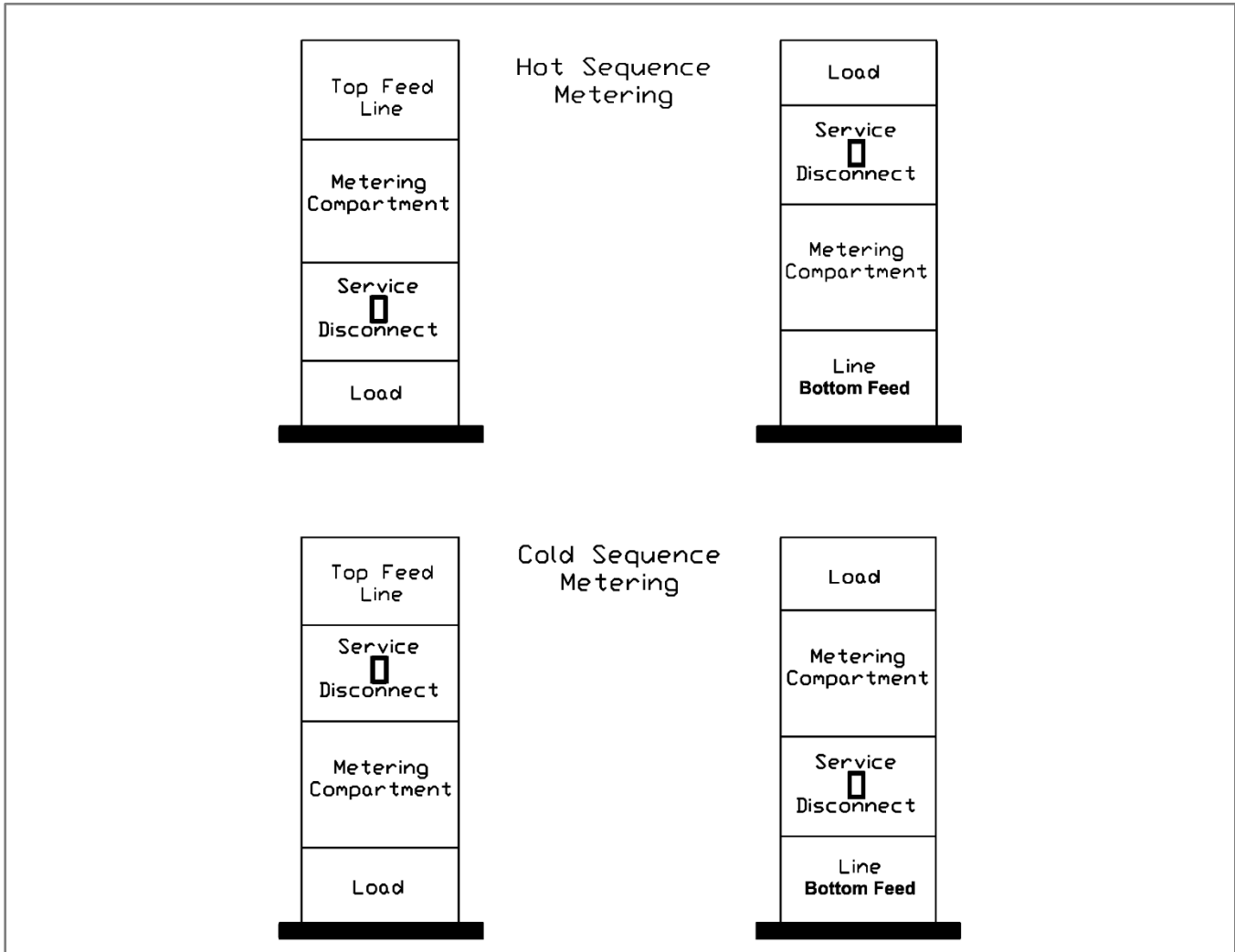

Note to Figure 7.4.6.2-1:

Cold sequence metering is required on the network system. Refer to Electric System Bulletin 757 for network service.

Figure 7.4.6.6-1: Metering Instrument Transformer Compartment in Service Cubicles Rated 600V (Shown for Hot Sequenced Metering)

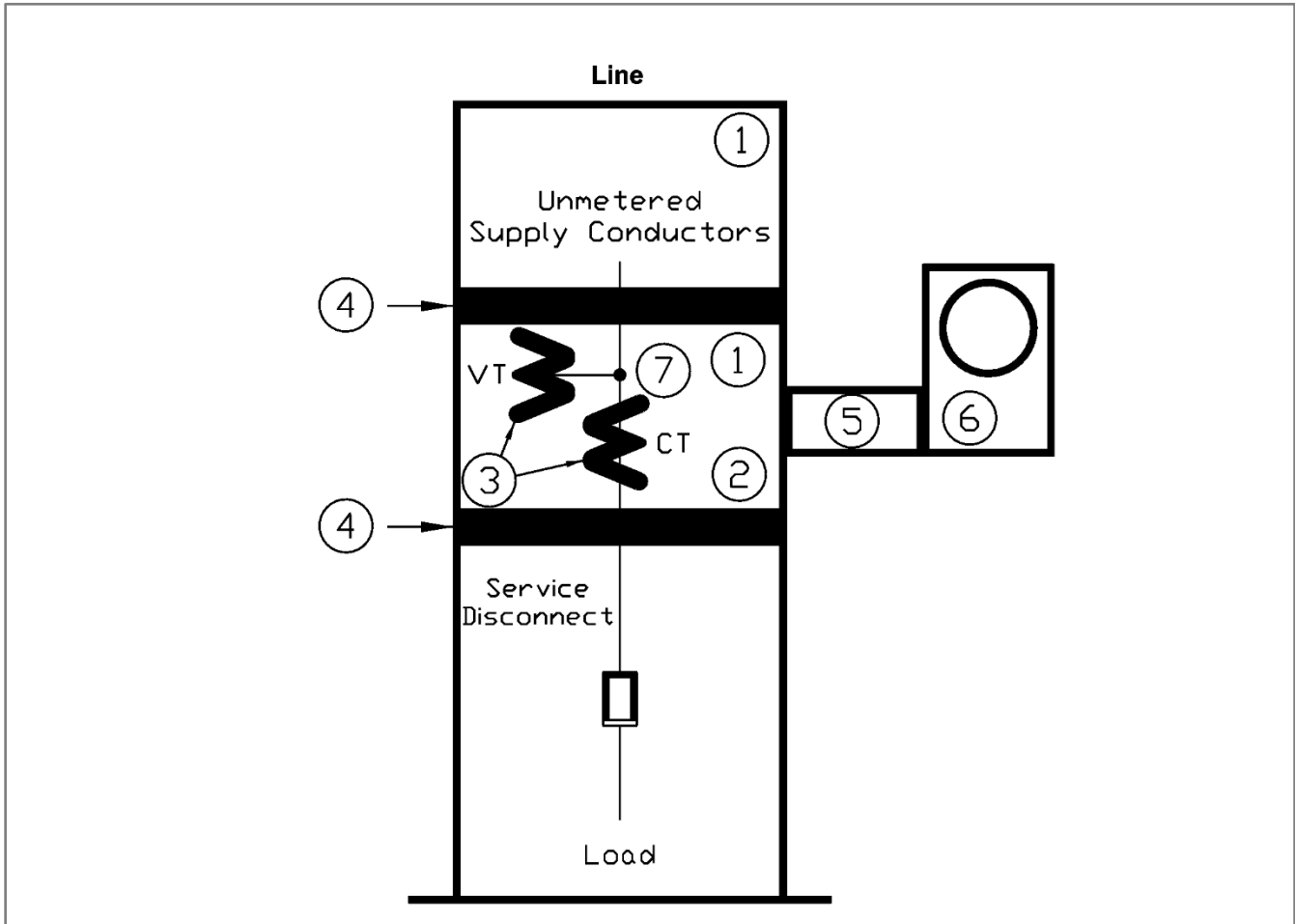

Notes for Figure 7.4.6.6-1:

- (A) (Figure Note 1) Compartments Lockable.
- (B) (Figure Note 2) Instrument transformer compartment.
- (C) (Figure Note 3) Metering transformer supplied by the Company. Voltage Transformers (VT's) supplied where required by Company.
- (D) (Figure Note 4) Insulating barriers.
- (E) (Figure Note 5) 1-1/2" Rigid Galvanized Steel conduit.
- (F) (Figure Note 6) Company provided meter socket enclosure mounted adjacent to service cubicle.
- (G) (Figure Note 7) A means of connection shall be provided in the metering transformer compartment for purposes of connecting the metering control circuit neutral to the incoming service neutral.

Figure 11.2.1-1: Standby Generator Transfer Switch Arrangements

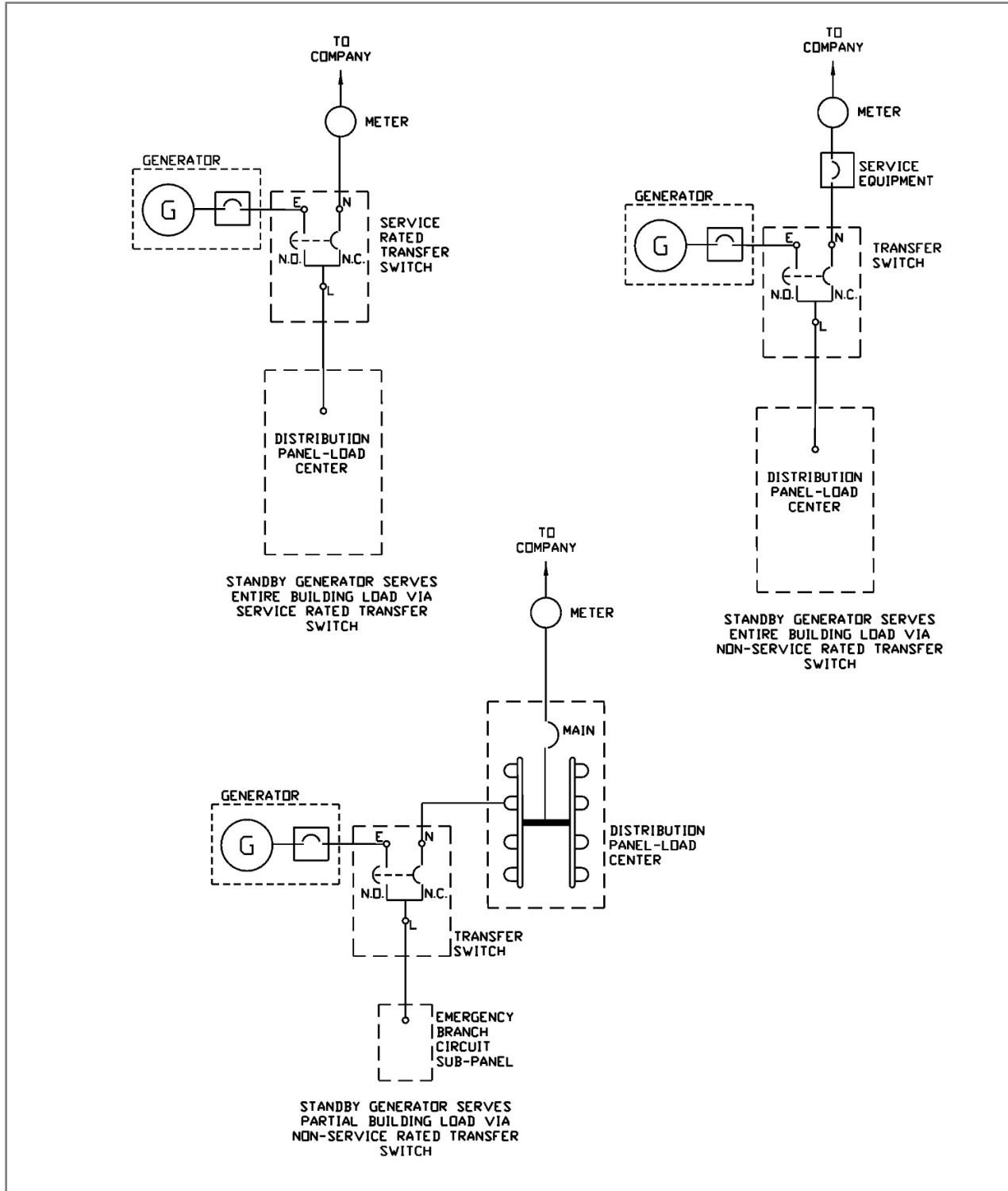

Note to Figure 11.2.1-1:

These figures are shown for hot sequence. The installation will vary for cold sequence and transformer rated installations.

THIS PAGE INTENTIONALLY LEFT BLANK

Part C – APPENDICES

APPENDIX 1 - OVERHEAD ATTACHMENT METHODS

Overhead service attachment brackets shall be of Company approved materials.

Table APP1-1: Company Accepted Attachment Materials

Item #	Note	Description	Manufacturer	Mfg. Cat. #.
B53A		Bracket, insulated service. Reinforced porcelain wire holder for attachment of multiplex services to 2-1/2" metal mast.	Joslyn Cooper	J0588Z DW2C5
B53B		Bracket, insulated service. Reinforced porcelain wire holder for attachment of multiplex services to 3" to 4" metal mast.	Chance PPC Insul	C207-0076 6913
B54	(A)	Bracket, insulated service. "House Knob."	Chance	C207-0076
B20A	(B)	Galvanized ferris eyelet, for use with preformed deadends. NEMA Standard PH5.	Allied Bolt Cooper Joslyn Maclean Richards Mfg. Utilities Svc	2050 DG5E1 J6550-C TE-5 RTMBE-1 5529
I11	(B)	Clevis, insulated spool type sec. dead-end EEI-TD20-Item 2 clevis with ANSI C29.3 Class 53-3 insulator.	Cooper Chance	DC3F6 0340
I12	(B)	Clevis, secondary insulator clevis; galv. steel for use with I-25 insulator (not included); 3000# ult. For use on #1/0 AWG & 336 kcmil triplex services. 5/8" cotter bolt & s.s. cotter key.	Chance	C207-0072
I25	(B)	Insulator, sec. rack spec. ANSI C29.3-class 53-2, 0-600V.	Joslyn Cooper PPC Insul. Victor Ins. Lapp	J151 DE455 5101 VI2612 8442-70
B7A2	(B)	2 1/2" Expansion Shield Lag Screw, cast of zinc-base alloy. Long style for use with 3/8" lag screws on masonry construction.	Rawl Star	1155 1825-00200
B11A	(B)	3/8" x 3" Galv. Steel Lag Screw, with square head shoulder shank and gimlet point.	Cooper Joslyn Allied Bolt	DF3L3 J8773 582
B11B	(B)	3/8" x 4" Galv. Steel Lag Screw, with square head shoulder shank and gimlet point.	Cooper Allied Bolt Hughes Bros.	DF3L4 582 LS34
B13	(B)	Machine Bolt, 5/8" x 12" square head steel bolt (with nut). Galv. Steel with 6" min. thread length.	Chance Hughes Cooper Allied Bolt Joslyn	8812 B612-4 DF3B12 8824 J8812
W1	(B)	Flat Washer, 2-1/4" square x 3/16" Galv. Steel	Chance Joslyn Cooper Allied Bolt	6814 J1076 DF2W5 11550

Notes to Table:

- (A) For up to 600 lbs. service drop tension only.
- (B) For up to 2000 lbs. service drop tension only.

Refer to the illustrations that follow for Company-accepted attachment methods.

Figure App1-1: Illustrated Details of Overhead Service Attachment Methods

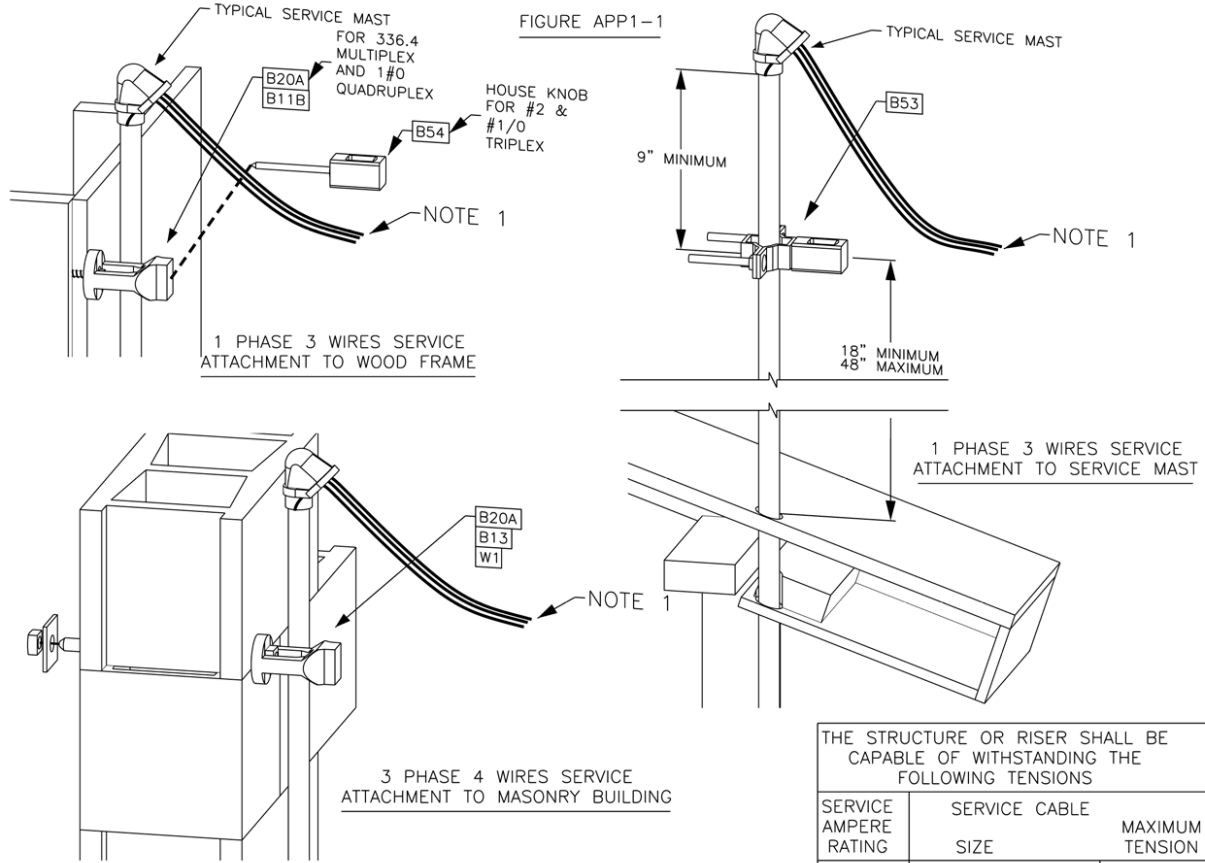

THE STRUCTURE OR RISER SHALL BE CAPABLE OF WITHSTANDING THE FOLLOWING TENSIONS

SERVICE AMPERE RATING	SERVICE CABLE SIZE	MAXIMUM TENSION
150	#2 TRIPLEX	650 LBS.
200(1 ϕ)	#1/0 TRIPLEX	650 LBS.
200(3 ϕ)	#1/0 QUADRUPLIX	680 LBS.
400	#336.4 TRIPLEX	1000 LBS.
600	OR QUADRUPLIX	2000 LBS.

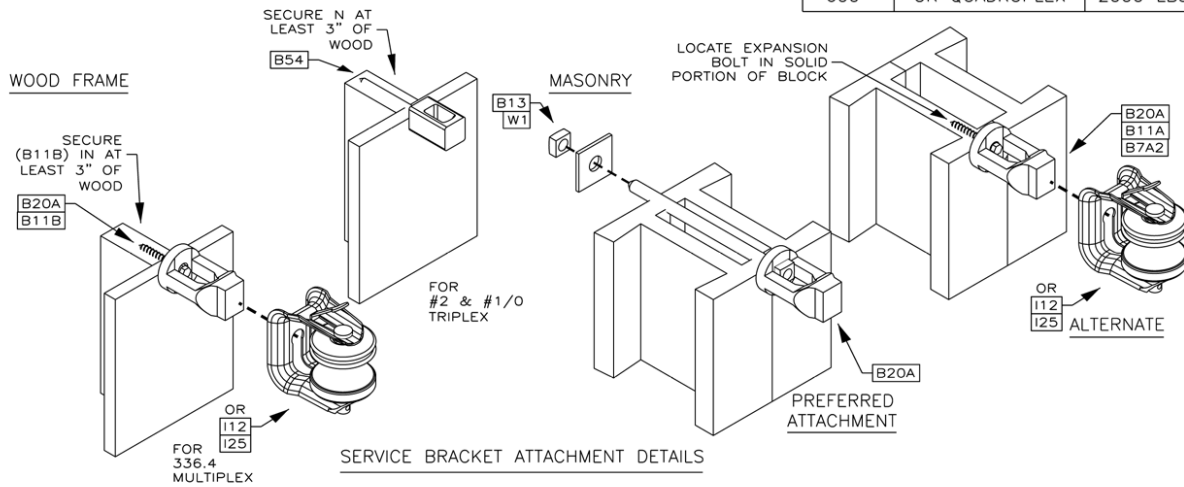

NOTE:
 1. LEAVE A MINIMUM OF 36" OF SERVICE ENTRANCE CONDUCTOR BEYOND THE WEATHERHEAD FOR SERVICE CONNECTION BY THE COMPANY.

APPENDIX 2 - TRAFFIC CONTROL METERED SERVICE REQUIREMENTS

(For D.O.T., Municipal, and individual Customers as designated in the Company's applicable tariff.)

Figure App2-1: Typical Traffic Control Metered Service Installation

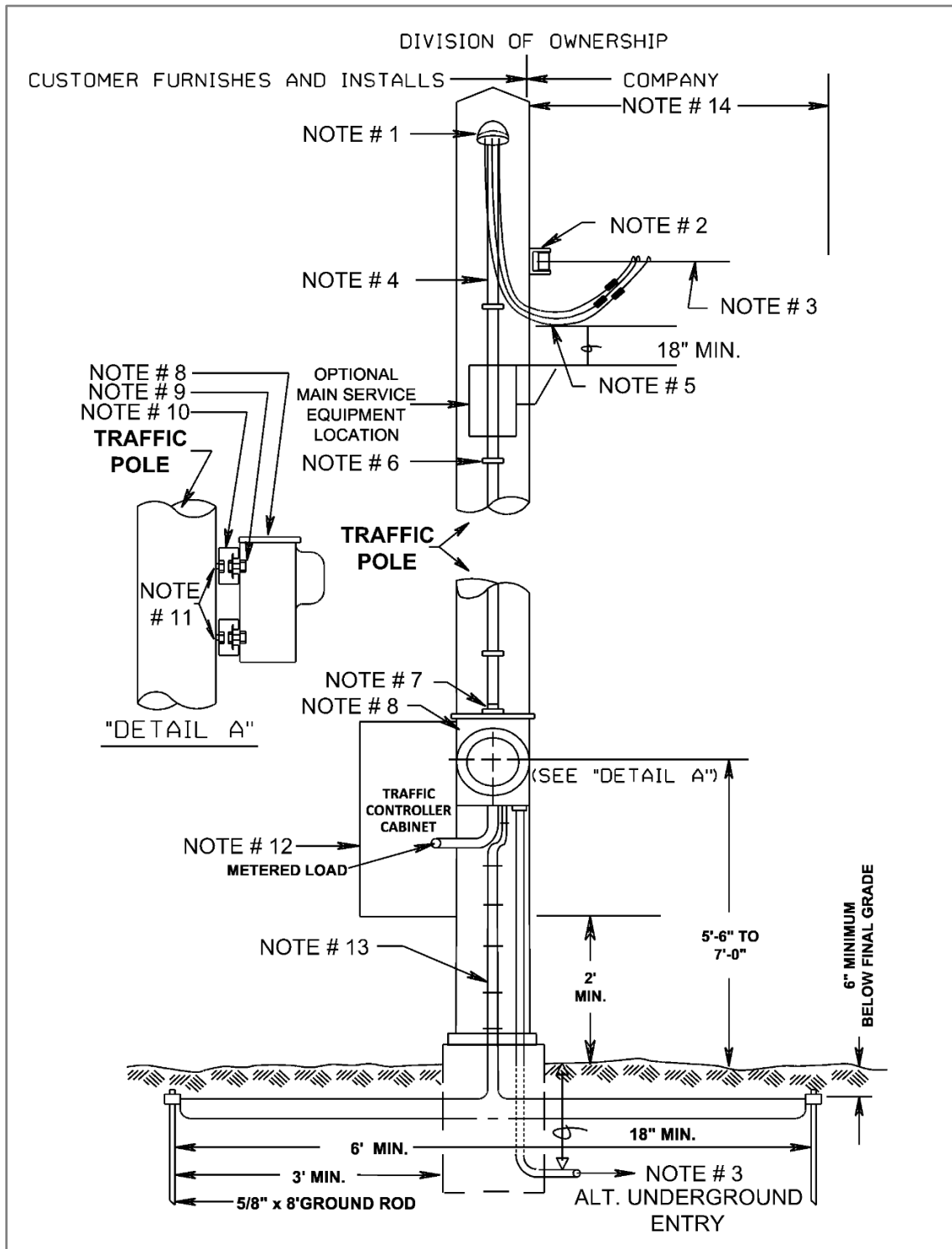

Notes for Figure App2-1:

(The figure is typical in nature; however, variations may be permitted with prior consultation with the Company and approval granted in writing.)

- (A) (Figure Note 1) Raintight service head (weatherhead).
- (B) (Figure Note 2) Service bracket furnished and installed by Customer below weatherhead.
- (C) (Figure Note 3) Company service drop for overhead service. For underground service, Customer's cable-in-conduit (continuous) to Company's line.
- (D) (Figure Note 4) Service entrance conductors in approved conduit. PVC Schedule 80 recommended, see [Section 4.0](#). Bond metallic conduit in accordance with N.E.C. Article 250.
- (E) (Figure Note 5) A minimum of 36" of service entrance conductor shall be extended beyond the weatherhead for service connection by the company.
- (F) (Figure Note 6) Straps at not more than 30" intervals.
- (G) (Figure Note 7) Watertight fitting.
- (H) (Figure Note 8) Commercial meter socket enclosure furnished and installed by Customer in a true vertical position, see [Section 7.0](#). Locate on structure away from traffic flow and such that the bottom of the meter socket enclosure is more than 8 ft above grade. Or, the top of the meter socket enclosure must be below 6 ft and there must be 8 ft clear space without handholds or footholds starting at no higher than 6 ft above grade. For service supplied from a network, a main disconnect is required and metering shall be cold-sequence.
- (I) (Figure Note 9) 1/4" dia. x 3/4" long bolts with nut and washer, all zinc coated steel. A total of four (4) required, two (2) for top, two (2) for bottom.
- (J) (Figure Note 10) Slotted framing channel (Kindorf, Unistrut, Superstrut, or Company accepted equal), 12-gauge zinc coated steel, with holes, 1-1/2" h x 3/4" w x (length = width of associated meter socket enclosure). Two required, one for top, one for bottom.
- (K) (Figure Note 11) Meter support attached to Customer's structure with materials approved for the purpose.
- (L) (Figure Note 12) Outdoor service equipment, see [Section 5.0](#). For transfer switch applications, refer to [Section 12.0](#). Where in the public way and the Customer's structure is connected to the Company's overhead service drop, traffic controller equipment and service equipment shall be located such that the bottom of the equipment is more than 8 ft above grade. Or, the top of the traffic control box must be below 6 ft and there must be 8 ft clear space without handholds or footholds starting at no higher than 6 ft above grade.
- (M) (Figure Note 13) Install service entrance ground in accordance with N.E.C.
- (N) (Figure Note 14) 10 ft minimum distance from service pole to Company's line, see [Section 4.0](#) regarding clearances.

An exception, regarding metering sequence, has been granted to metered Massachusetts State Highway traffic signal installations. An approved fused disconnect mounted on the pole is allowed ahead of the meter pedestal.

APPENDIX 3 - SWIMMING POOL CLEARANCE CRITERIA

National Grid shall use the criteria within Appendix 3 to determine the allowable clearance between overhead conductors and swimming pools and swimming pool related structures.

(A) Criteria 1

The Company's overhead conductors are not to be located within 10 ft, horizontally, of a swimming pool, diving platform, diving tower, water slide, or other fixed, pool-related structure as illustrated by the dashed line (Perimeter P) in Figure App3 -1. Likewise, a swimming pool, diving platform, diving tower, water slide, or other fixed, pool-related structure is not to be located within 10 ft, horizontally, of an overhead conductor. Overhead conductors outside the 10 ft perimeter must also meet the clearance requirements illustrated in Table App3-1 and Figure App3-2. See Note (B) of Table App3-1 for 0V to 750V multiplex cable.

Figure App3-1: Swimming Pool Perimeter

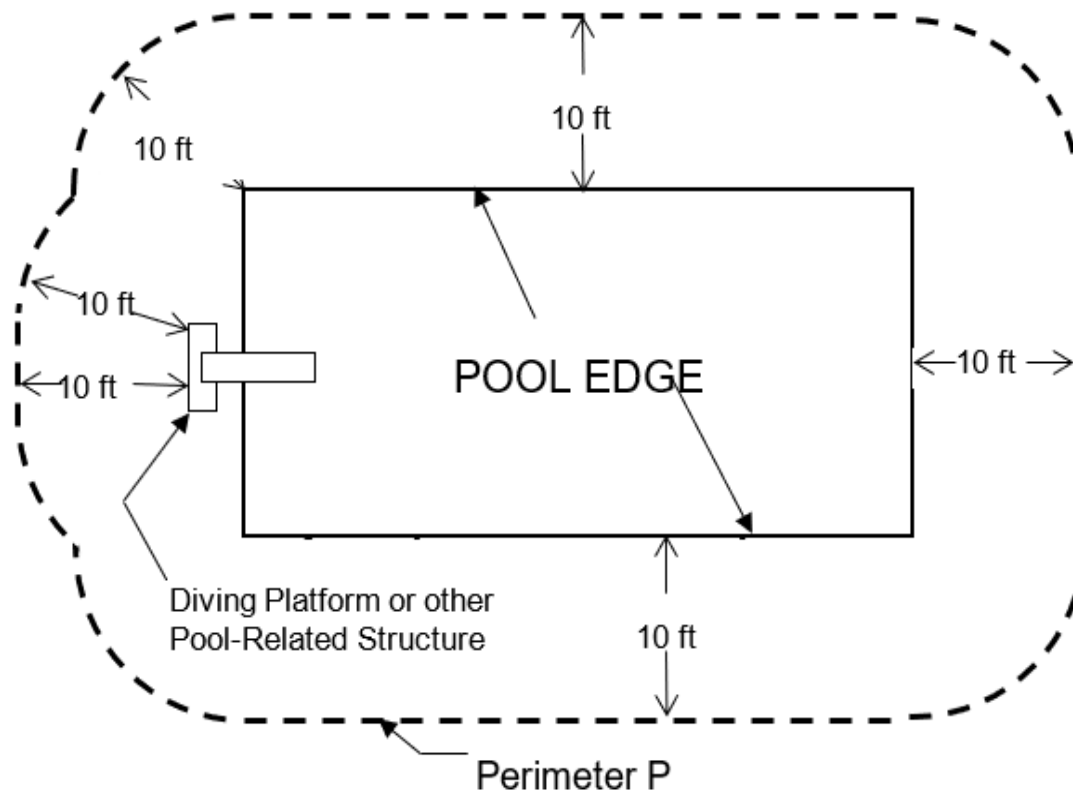

Note for Figure App3-1: Overhead conductors are not to be located within Perimeter P.

(B) Criteria 2

If it is not physically practical to implement Criteria 1 within the property, then overhead conductors will be allowed within the dotted Perimeter P of Figure App3-1, but in accordance with the clearance requirements illustrated in Table App3-1 and Figure App3-2.

Table App3-1: Clearances Over or Near Swimming Pools (See Note (D))

Clearances Over or Near Swimming Pools (See Note (D)) <i>Voltages are Phase-to-Ground for Effectively Grounded Systems</i>				
Figure App3-2 Dimension	Effectively Grounded Neutral, Grounded Guys, Ungrounded Guys Exposed to 300V or Less (See Note (A)), and Fully Shielded Lashed Aerial Cable (See Note (B))	0 to 750V Multiplex Cable (See Notes (B) & (C)) and Ungrounded Guys Exposed to 300V to 750V (See Note (A))	0 to 750V Open Conductor, and Semi-Conductor Shielded or Unshielded Lashed Aerial Cable	750V to 22kV Conductor (Bare, Covered, Tree Wire or Spacer Cable) (See Note (E))
A	23.5 ft	24.0 ft	24.5 ft	26.5 ft
B	15.5 ft	16.0 ft	16.5 ft	18.5 ft
V	The clearance shall be as required in Table 4.2.4.1-1 .			

Notes for Table App3-1:

- (A) Ungrounded guys shall be considered on a case by case basis.
- (B) These clearances do not apply to effectively grounded neutrals, guys, fully shielded lashed aerial cable or 0V to 750V multiplex cable when these facilities are 10 ft or more horizontally from the edge of the pool, diving platform, diving tower, water slide or other fixed, pool-related structures.
- (C) Does not include multiplex cables with an insulated neutral.
- (D) The vertical clearance values for conductors are for 100 ft spans at 60°F final unloaded sag and phase-to-ground voltages. No allowance is made for sag for vertical clearances at a building or structure's point of attachment. The Company will increase the clearances required for longer spans.
- (E) Voltages above 22 kV, phase-to-ground, will be handled on a case by case basis.

Figure App3-2: Swimming Pool Clearance References

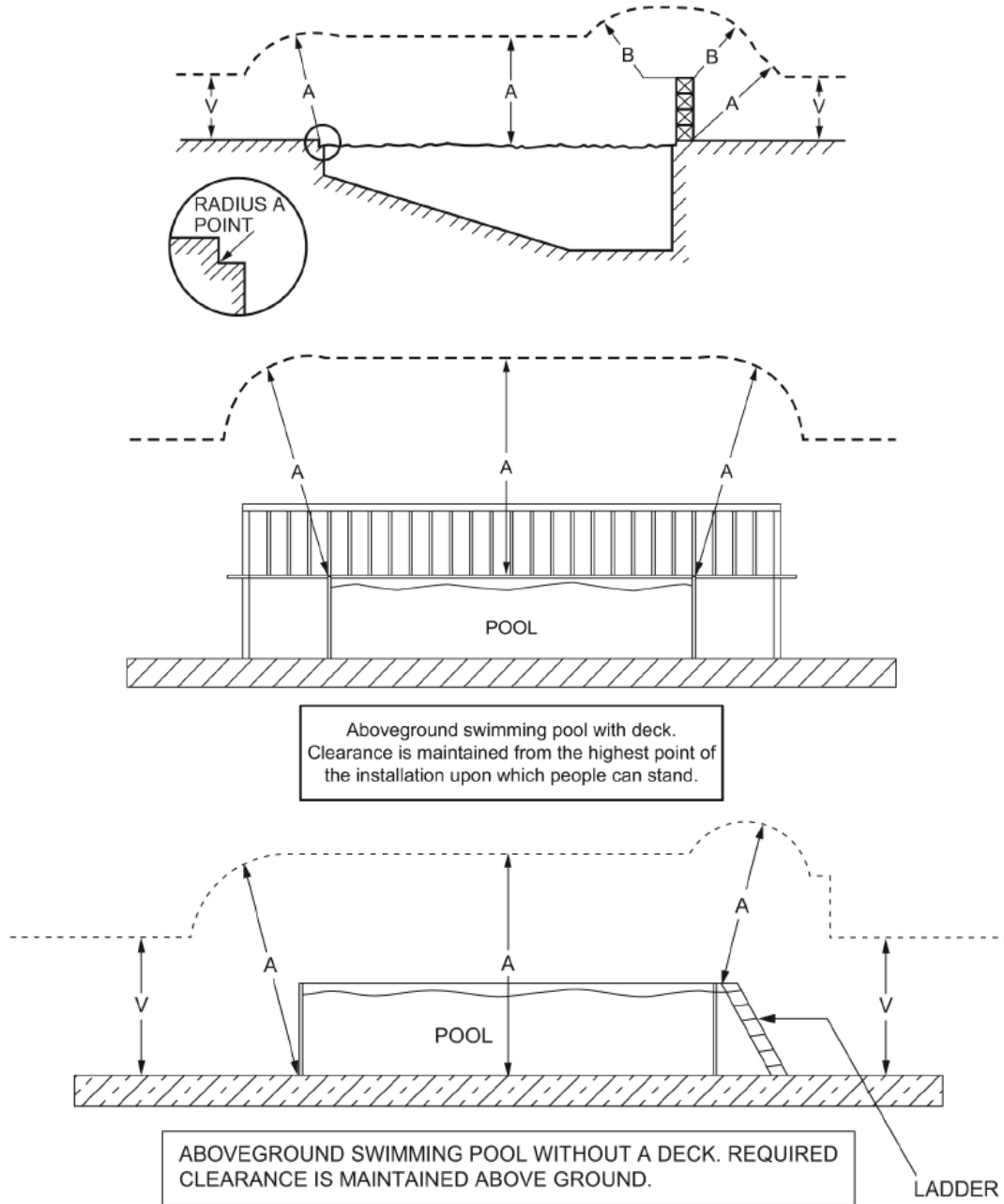

Notes to Figure App3-2:

- (A) Dimension A: Clearance in any direction from the water level, edge of pool, base of diving platform, or anchored raft.
- (B) Dimension B: Clearance in any direction to the diving platform, tower, water slide, or other fixed pool related structures.
- (C) Dimension V: The dimension from [Table 4.2.4.1-1](#), the applicable of the first, second, or fifth row.

APPENDIX 4 - ELECTRIC SERVICE AREAS

Figure App4.1: National Grid’s Electric Service Territory in Massachusetts (MA)

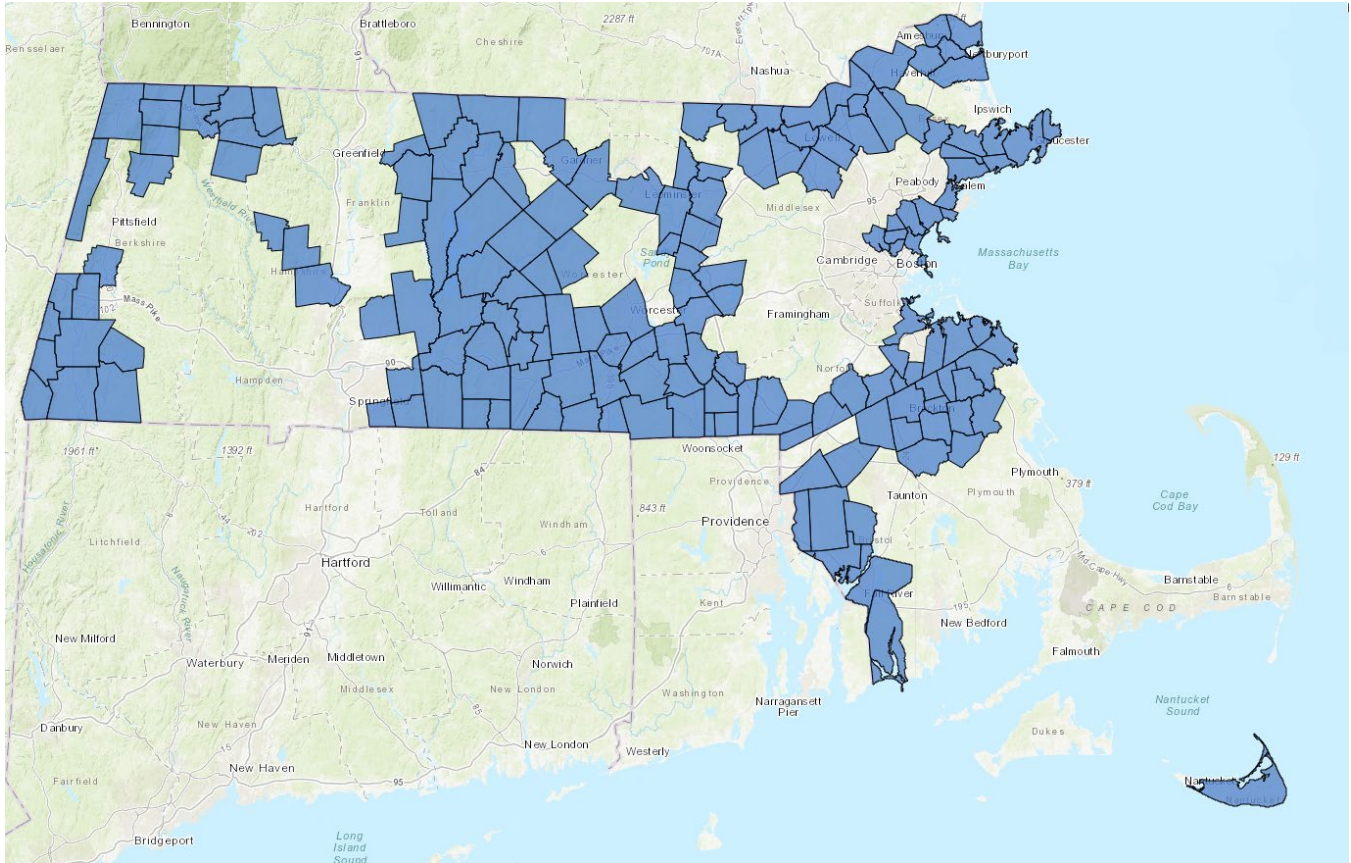

SERVING THESE COMMUNITIES IN MA:

- | | | | |
|------------------|-----------------|------------|------------------|
| Abington | Adams | Alford | Amesbury |
| Andover | Athol | Attleboro | Auburn |
| Avon | Ayer | Barre | Belchertown |
| Bellingham* | Berlin | Beverly | Billerica |
| Blackstone | Bolton | Boxford | Bridgewater |
| Brimfield | Brockton | Brookfield | Charlemont |
| Charlton | Chelmsford | Cheshire | Clarksburg |
| Clinton | Cohasset | Dighton* | Douglas |
| Dracut | Dudley | Dunstable | East Bridgewater |
| East Brookfield | East Longmeadow | Easton | Egremont |
| Erving* | Essex | Everett | Fall River |
| Florida | Foxboro | Franklin | Gardner |
| Gloucester | Goshen | Grafton | Granby |
| Great Barrington | Halifax | Hamilton | Hampden |
| Hancock | Hanover | Hanson | Hardwick |
| Harvard | Haverhill | Hawley | Heath |
| Holbrook | Holland | Hopedale | Hubbardston |
| Lancaster | Lawrence | Leicester | Lenox |
| Leominster | Lowell | Lynn | Malden |
| Manchester | Marlborough | Medford | Melrose |

Mendon	Methuen	Milford	Millbury
Millville	Monroe	Monson	Monterey
Mt Washington	Nahant	New Braintree	New Marlboro
New Salem	Newbury	Newburyport	North Adams
North Andover	North Brookfield	Northampton	Northborough
Northbridge	Norton	Norwell	Oakham
Orange	Oxford	Palmer	Pembroke*
Pepperell	Petersham	Phillipston	Plainville
Quincy	Randolph	Rehoboth	Revere
Rockdale	Rockport	Rowe	Royalston
Rutland	Salem	Salisbury	Saugus
Scituate*	Seekonk	Sheffield	Shirley
Shutesbury	Somerset	Southborough	Southbridge
Spencer	Stockbridge	Stoughton	Sturbridge
Sutton	Swampscott	Swansea	Tewksbury
Topsfield	Nantucket	Tyngsborough	Upton
Uxbridge	Wales	Ware	Warren
Warwick	Webster	Wendell	Wenham
West Bridgewater	West Brookfield	West Newbury	West Stockbridge
Westborough	Westford	Westminster	Westport*
Weymouth	Wilbraham	Williamsburg	Williamstown
Winchendon	Winthrop	Worcester	Wrentham
			<i>*Served in part</i>

Figure App4.2: National Grid’s Electric Service Territory in Upstate New York

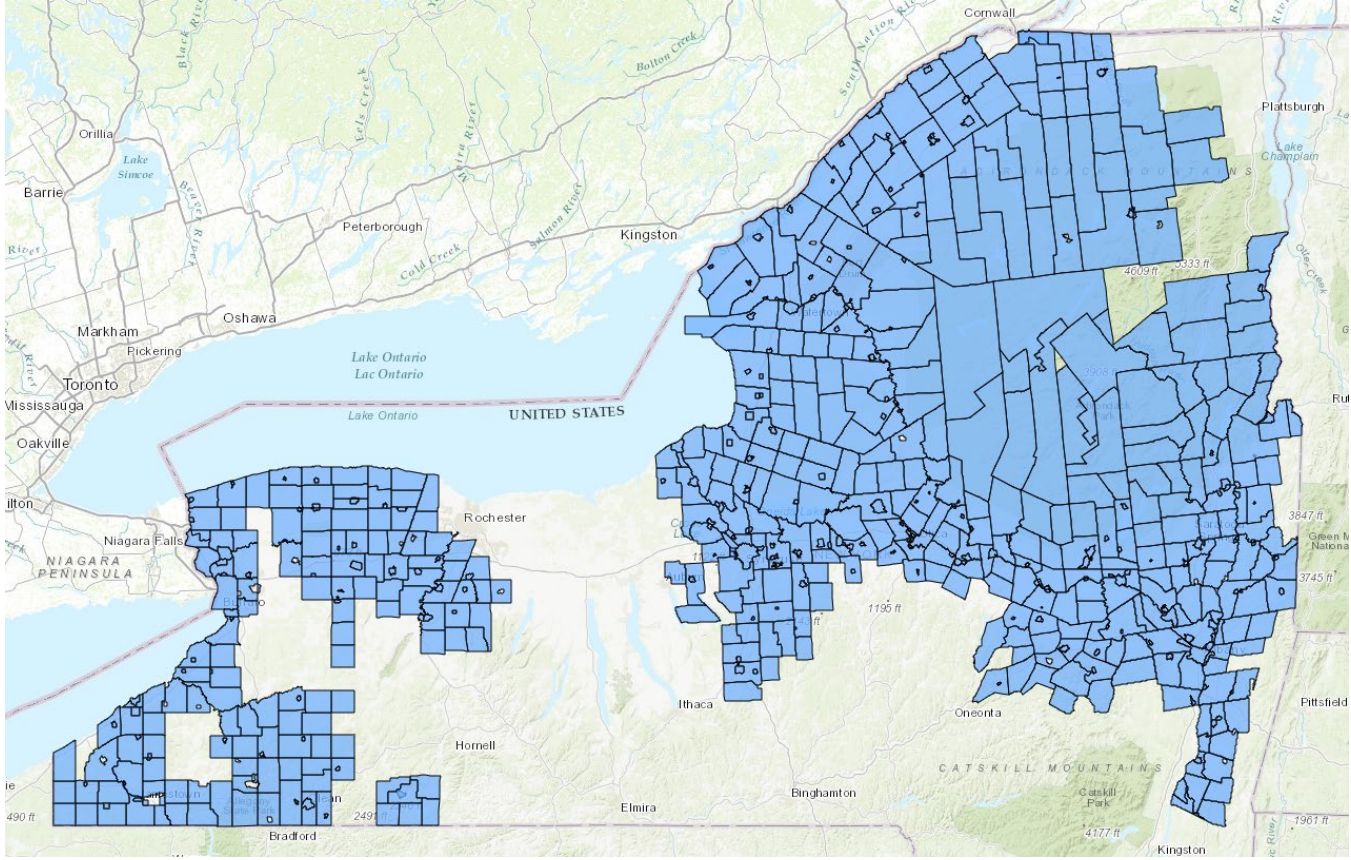

SERVING THESE COMMUNITIES: (See the following pages for NY’s Western, Central, and Eastern divisions.)

NY Western Division Service Area Cities (C), Towns (T), and Villages (V) by County

Allegany →	T Alma	T Andover*	T Centerville
T Cuba	T Independence	T New Hudson	T Scio
T Wellsville*	T Willing	V Cuba	
Cattaraugus →	C Olean	T Allegany	T Ashford
T Carrollton	T Cold Spring	T East Otto	T Ellicottville
T Farmersville	T Franklinville	T Freedom*	T Great Valley*
T Hinsdale	T Humphrey	T Ischua	T Little Valley*
T Lyndon	T Machias	T Mansfield	T Olean
T Otto	T Perrysburg*	T Portville	T Randolph*
T Redhouse	T South Valley	T Yorkshire*	V Allegany
V Cattaraugus	V Delevan	V Franklinville	V Limestone
V Portville			
Chautauqua →	C Dunkirk	T Arkwright	T Busti
T Carroll	T Charlotte	T Chautaugua*	T Clymer
T Dunkirk	T Ellery	T Ellicott	T French Creek
T Gerry	T Harmony	T Kaintone	T Mina
T North Harmony	T Poland	T Pomfret	T Portland*
T Ripley	T Sheridan	T Sherman	T Stockton

V Bermus Point	V Brockton*	V Cassadaga	V Celeron
V Falconer*	V Fredonia	V Lakewood	V Panama
V Sherman	V Sinclairville-Charlotte	V Sinclairville-Gerry	V Westfield*
Erie →	C Buffalo	C Lackawanna	C Tonawanda
T Amherst*	T Brant	T Cheektowaga*	T Collins
T Eden	T Evans	T Grand Island	T Hamburg*
T Newstead*	T North Collins	T Tonawanda	T West Seneca*
V Angola	V Blasdell	V Depew-Cheektowaga*	V Depew-Lancaster*
V Ellicottville	V Farmham	V Kenmore	V Lancaster
V North Collins	V Sloan-Cheektowaga*	V Williamsville-Amherst	
Genesee →	C Batavia	T Alabama	T Alexander
T Batavia	T Bergen*	T Bethany	T Byron
T Darien	T Elba	T LeRoy	T Oakfield
T Pavilion	T Pembroke	T Stafford	V Alexander
V Attica - Alexander	V Attica - Attica	V Corfu	V Elba
V LeRoy	V Oakfield		
Livingston →	T Avon	T Caledonia	T Conesus
T Geneseo*	T Groveland	T Lima	T Livonia
T York	V Avon	V Caledonia	V Lima
V Livonia			
Monroe →	T Clarkson	T Hamlin	T Mendon*
T Riga*	T Rush	T Sweden	V Brockport – Sweden
V Honeoye Falls	V Scottsville		
Niagara →	C Niagara Falls	C North Tonawanda	T Cambria
T Hartland	T Lewiston	T Lockport*	T Newfane
T Niagara	T Pendleton	T Porter	T Royalton
T Somerset	T Wheatfield	T Wilson	V Lewiston
V Middleport-Hartland	V Middleport-Royalton	V Wilson	V Youngstown
Ontario →	T Canadice	T Richmond	T West Bloomfield
Orleans →	T Albion	T Barre	T Carlton
T Clarendon	T Gaines	T Kendall	T Murray*
T Ridgeway	T Shelby	T Yates	V Albion – Albion
V Albion - Gaines	V Barker	V Holley	V Lyndonville
V Medina - Ridgeway	V Medina - Shelby		
Wyoming →	T Attica	T Covington	T Orangeville
T Wethersfield			

**Served in part*

NY Central Division Service Area Cities (C), Towns (T), and Villages (V) by County

Cayuga →	T Niles		
Chenango →	T Lincklaen		
Clinton →	T Black Brook	T Saranac*	
Cortland →	C Cortland	T Cortlandville	T Cuyler
T Homer	T Preble	T Scott	T Solon
T Truxton	T Virgil*	V Homer	V Homer-Cortlandville
V McGraw			
Essex →	T North Elba*	T St. Armand	V Bloomingdale
	V Saranac Lake - N		
V Lake Placid - N Elba*	Elba	V Saranac Lk - St Armand	
Franklin →	T Altamont	T Bangor	T Belmont*
T Bombay	T Brandon	T Brighton	T Constable*
T Dickinson	T Duane	T Fort Covington	T Franklin
T Harrietstown	T Malone	T Moira	T Santa Clara
T Waverly	T Westville	V Brushton	V Fort Covington
	V Saranac Lake-		
V Malone	Harr'town	V Tupper Lk-Altamont*	
Fulton →	T Oppenheim	T Stratford	V Dolgeville*
Hamilton →	T Arietta	T Inlet	T Inlet
T Long Lake*	T Morehouse		
Herkimer →	C Little Falls	T Columbia*	T Danube
T Fairfield	T Frankfort	T German Flatts	T Herkimer
T Litchfield*	T Little Falls	T Manheim	T Newport
T Norway	T Ohio	T Russia	T Salisbury
T Schuyler	T Webb	V Cold Brook	V Dolgeville - Manhiem
V Frankfort*			
Jefferson →	C Watertown	T Adams	T Alexandria
T Antwerp	T Brownville	T Cape Vincent	T Champion
T Clayton	T Ellisburg	T Henderson	T Hounsfield
T LeRay	T Lorraine	T Lyme	T Orleans
T Pamela	T Philadelphia*	T Rodman	T Rutland
T Theresa	T Watertown	T Wilna	T Worth
V Adams	V Alexandria Bay	V Antwerp	V Black River-LeRay
V Black River-Rutland	V Brownville	V Cape Vincent	V Carthage
V Chaumont	V Clayton	V Deferiet	V Dexter
		V Glen Park -	
V Ellisburg	V Evans Mills	Brownville	V Glen Park – Pamela
V Herrings	V Mannsville	T Orwell	T Oswego
T Palermo	V Philadelphia*	V Sackets Harbor	V Theresa*
V West Carthage			
Lewis →	T Constableville	T Croghan	T Denmark
T Diana	T Greig	T Harrisburg	T High Market
T Lewis	T Leyden	T Lowville	T Lyonsdale
T Martinsburg	T Montague	T New Bremen*	T Osceola
T Pinckney	T Turin	T Watson	T West Turin

V Castorland	V Constableville	V Copenhagen	V Croghan
V Croghan - New Bremen	V Harrisville	V Lowville	V Lyons Falls
V Lyons Falls - Lyonsdale	V Port Leyden	V Port Leyden-Lyonsdale	V Turin
Madison →	C Oneida – Inside	C Oneida - Outside	T Cazenovia
T DeRuyter	T Fenner	T Lenox	T Lincoln
T Nelson	T Stockbridge	T Sullivan	V Canastota
V Cazenovia	V Chittenango	V DeRuyter	V Munnsville
V Wampsville			
Oneida →	C Rome - Inside	C Rome - Outside	C Utica
T Annsville	T Ava*	T Boonville*	T Camden
T Deerfield	T Florence	T Floyd	T Forestport
T Kirkland	T Lee	T Marcy	T New Hartford
T Paris	T Remsen	T Stueben	T Trenton
T Vernon	T Verona	T Vienna	T Western
T Westmoreland	T Whitestown	V Boonville*	V Camden
V Clayville	V Clinton	V Holland Patent	V Herkimer
V Ilion*	V Middleville-Fairfield	V Middleville-Newport	V Mohawk*
		V New York Mills-Whitestown	V NY Mills-New Hartford
V New Hartford	V Newport	V Poland – Newport	V Poland – Russia
V Oneida Castle	V Oriskany	V Remsen - Trenton	V Sherrill*
V Prospect	V Remsen	V Vernon	V Whitesboro
V Sylvan Beach	V Trenton		
V Yorkville			
Onondaga →	C Syracuse	T Camillus	T Cicero
T Clay	T Dewitt	T Elbridge*	T Fabius
T Geddes*	T Lafayette	T Lysander	T Manlius
T Onondaga	T Otisco*	T Pompey	T Salina
			V Baldwinsville-Lysander
T Skaneateles*	T Tully	T Van Buren	
V Baldwinsville-Van Buren	V Camillus	V East Syracuse	V Fabius
V Fayetteville	V Liverpool	V Manlius	V Minoa
V North Syracuse-Cicero	V North Syracuse-Clay		V Skaneateles*
V Solvay*	V Tully		
Oswego →	C Fulton	C Oswego	T Albion
T Amboy	T Boylston	T Constantia	T Granby
T Hannibal	T Hastings	T Mexico	T Minetto
T New Haven	T Orwell	T Oswego	T Palermo
T Parish	T Redfield	T Richland	T Sandy Creek
T Schroepfel	T Scriba	T Volney	T West Monroe
T Williamstown	H Altmar	V Central Square	V Cleveland
V Hannibal	V Lacona	V Mexico	V Parish
V Phoenix	V Pulaski	V Sandy Creek	
St Lawrence →	C Ogdensburg	T Brasher*	T Canton

T Clare	T Clifton	T Colton	T DeKalb
T DePeyster	T Edwards	T Fine	T Fowler
T Gouverneur	T Hammond	T Hermon	T Hopkinton
T Lawrence	T Lisbon	T Louisville*	T Macomb
T Madrid	T Massena*	T Morristown	T Norfolk*
T Oswegatchie	T Parishville	T Piercefield	T Pierrepont
T Pitcairn	T Potsdam	T Rossie	T Russell
T Stockholm*	T Waddington	V Canton	V Edwards
V Gouverneur	V Hammond	V Hermon	V Heuvelton
V Massena*	V Morristown	V Norwood - Norfolk	V Norwood – Potsdam
V Potsdam	V Rensselaer Falls	V Richville	V Waddington

**Served in part*

NY Eastern Division Service Area Cities (C), Towns (T), and Villages (V) by County

Albany →	C Albany	C Cohoes	C Watervliet
T Berne	T Bethlehem	T Coeymans*	T Colonie
T Guilderland	T Knox	T New Scotland	V Altamont
V Colonie	V Green Island*	V Menands	V Voorheesville
Columbia →	C Hudson	T Chatham*	T Claverack*
T Clermont	T Gallatin*	T Germantown	T Ghent
T Greenport	T Kinderhook	T Livingston	T Stockport
T Stuyvesant	T Taghkanic*	V Kinderhook	V Valatie
Essex →	T Crown Point	T Minerva	T Moriah
T North Hudson	T Schroon	T Ticonderoga	T Westport
V Port Henry	V Ticonderoga	V Westport	
Fulton →	C Gloversville	C Johnstown	T Bleecker
T Broadalbin	T Caroga	T Ephratah	T Johnstown
T Mayfield	T Northampton	T Oppenheim	T Perth
T Stratford	V Broadalbin	V Mayfield	V Northville
Hamilton →	T Arietta	T Benson	T Hope
T Indian Lake*	T Lake Pleasant	T Wells	V Speculator
Herkimer →	T Danube	T Manheim	T Stark
Montgomery →	C Amsterdam	T Amsterdam	T Canajoharie
T Charleston	T Florida	T Glen	T Minden
T Mohawk	T Palatine	T Root	T St. Johnsville
V Ames	V Canajoharie	V Fonda	V Fort Johnson
V Fort Plain - T		V Fort Plain - T	
Canajoharie	V Fort Plain - T Minden	Palatine	V Fultonville
V Hagaman	V Nelliston	V Palatine Bridge	
Otsego →	T Cherry Valley	T Decatur	T Maryland
T Roseboom	T Worcester	V Cherry Valley	V Schenevus
Rensselaer →	C Rensselaer	C Troy	T Brunswick
T E Greenbush	T Grafton	T Hoosick	T Nassau
T North Greenbush*	T Pittstown	T Poestenkill	T Sand Lake*
T Schaghticoke*	T Schodack	V Castleton	V Hoosick Falls

V Nassau - T Nassau	V Nassau - T Schodack	V Schaghticoke	V Valley Falls - T Pittstown
V Valley Falls - T	Schaghticoke		
Saratoga →	C Saratoga Springs	T Ballston	T Charlton
T Corinth	T Day	T Edinburgh	T Galway
T Greenfield	T Hadley	T Half Moon*	T Malta*
T Milton	T Moreau	T Northumberland	T Providence
T Saratoga	T Stillwater*	T Waterford	T Wilton
V Ballston Spa - T	V Ballston Spa - T		
Ballston	Milton	V Corinth	V Galway
V St. Johnsville	V Schuylerville	V So. Glens Falls	V Victory Mills
V Waterford			
Schenectady →	C Schenectady	T Duanesburg	T Glenville
T Niskayuna	T Princetown	T Rotterdam	V Delanson
V Scotia			
Schoharie →	T Blenheim	T Broome	T Carlisle
T Cobleskill	T Esperance	T Fulton	T Middleburg
T Richmondville*	T Schoharie	T Seward	T Sharon
T Summit	T Wright	V Cobleskill	V Esperance
V Middleburg	V Schoharie	V Sharon Springs	
Warren →	C Glens Falls	T Bolton	T Chester
T Hague	T Horicon	T Johnsbury	T Lake George
T Lake Luzerne	T Queensbury	T Stony Creek	T Thurman
T Warrensburg	V Lake George		
Washington →	T Argyle	T Cambridge	T Dresden
T Easton	T Fort Ann	T Fort Edward	T Greenwich
T Hampton	T Hartford	T Jackson*	T Kingsbury
T Putnam	T White Creek	T Whitehall	V Argyle
	V Cambridge - T	V Cambridge - T White	
V Broadalbin	Cambridge	Creek	V Fort Ann
	V Greenwich - T	V Greenwich - T	
V Fort Edward	Easton	Greenwich	V Hudson Falls
V Mayfield	V Northville	V Whitehall	

**Served in part*

SEIC LOG No. _____

CHANGE PROPOSAL FOR NATIONAL GRID

“SPECIFICATIONS FOR ELECTRICAL INSTALLATIONS”

INSTRUCTIONS — PLEASE READ CAREFULLY

Electronic media submittal of proposals is preferred. Type or print **legibly** in **black** ink. Use a separate copy for each proposal. Limit each proposal to a **SINGLE** section. All proposals must be received by National Grid’s SEIC to be considered for the next revision of **ESB 750**. Proposals received that are not in the prescribed format will be returned to the submitter. If supplementary material (photographs, diagrams, reports, etc.) is included, please submit one (1) printed copy and the electronic file copies in Adobe Acrobat (pdf) for the National Grid Specifications for Electrical Installations Committee (SEIC).

SUBMITTED BY: *(Include all appropriate information for contact purposes.)* DATE: _____

Name	Street Address/City/State/Zip/Email Address (or Internal Company Location)	Telephone No.

CHANGE PROPOSED FOR:

ESB Document No.	Section/Part/Paragraph/Article Reference
750 (2025)	

PROPOSED CHANGE: *(Include proposed new wording, or identification of wording to be deleted.)*

SUBSTANTIATION: *(Note: State the problem that will be resolved by your recommendation; give the specific reason for your proposal including copies of tests, research papers, fire or safety or operation experience, etc.)*

I understand that I acquire no rights in any publication of National Grid in which this change proposal in this or another similar or analogous form is used.

SIGNATURE: _____

Mail suggestions to:
 National Grid
 Distribution Planning and Asset Mgmt, Customer Facilities Engineer
 7496 Round Pond Road
 North Syracuse, New York, 13212

Or Email to:
seic@nationalgrid.com
 (electronic submittals are preferred)

Electrical Inspections are a Vital Public Safety Function

Inspections Can Save Lives and Property: Inspections by qualified inspectors reduce the potential for fire and shock hazards due to incorrectly installed electrical products and systems covered by the National Electrical Code®, save lives, and reduce property damage that may result from unsafe electrical installations.

Inspections Mean Compliance with Laws: Most states and localities require electrical installations to comply with the National Electrical Code®, to protect public safety. Electrical inspections help confirm that electrical wiring and systems are installed “according to Code.”

Inspections Check for Safety Products: Most states and localities require electrical products to be “listed” by recognized product safety certification organizations. Electrical inspections help confirm that properly certified products meeting U.S. safety standards are installed.

Inspections Confirm that Qualified Installers are on the Job: Electrical inspections protect against untrained or careless installers. Too often, unqualified installers perform unsafe electrical installations, and may also use products that don’t meet national safety requirements or local laws and codes.

No Public Funding: Government funding isn’t needed to pay for proper and thorough electrical inspections. The cost of inspections is usually covered by fees paid directly by builders and contractors. This vital public safety function doesn’t have to cost taxpayers or cash-strapped governments a dime.

Inspections Can Help Lower Insurance Premiums: Property insurance premiums are generally lower in areas with strong building codes enforced by professional inspectors. That’s because qualified electrical inspections help protect lives and property.

Signed by: The Inspection Initiative: An Industry Coalition Supporting Qualified Electrical Inspections (first issued 1997).

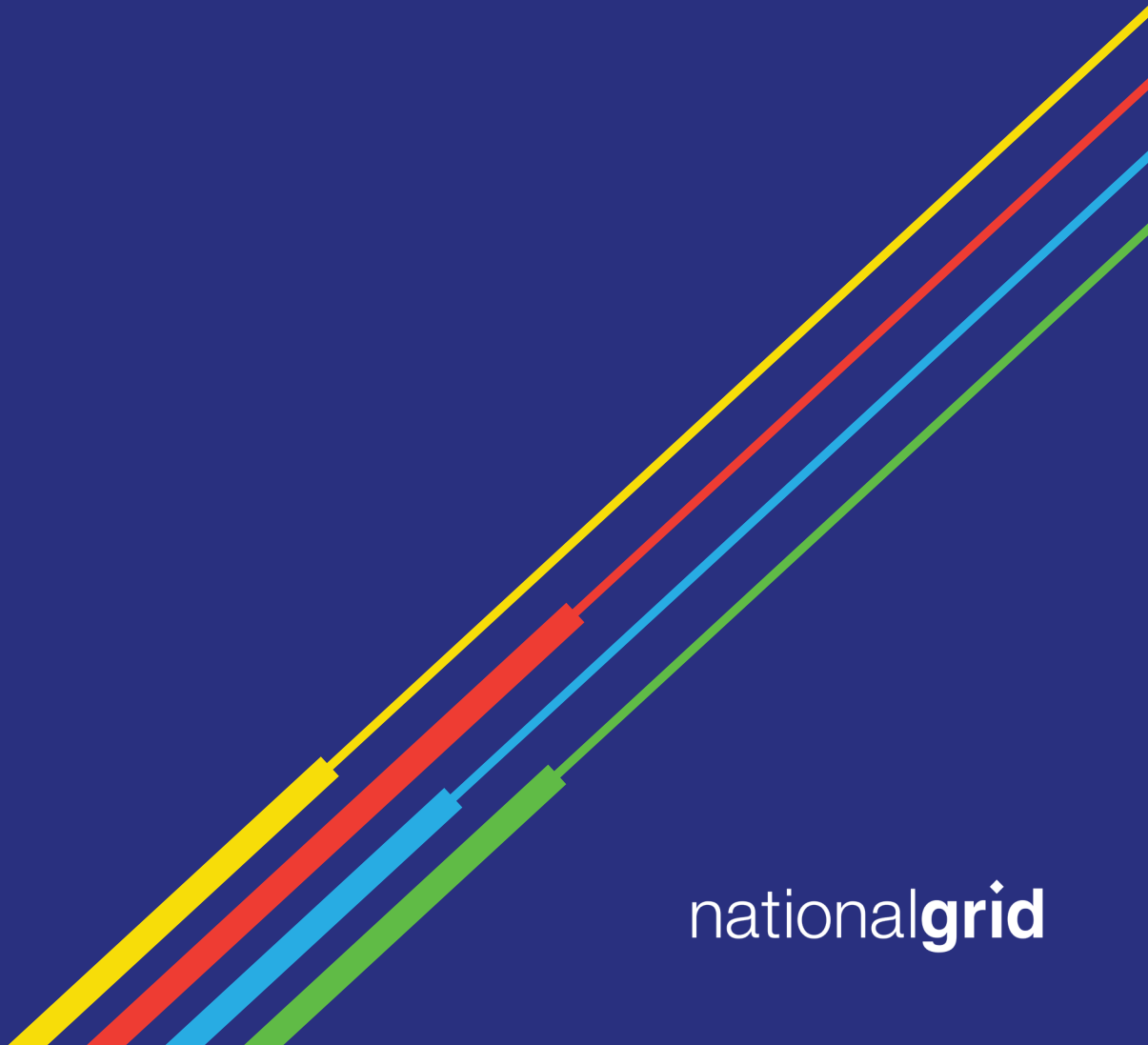

nationalgrid